

Training Book



Against Scale and Rust

Technology - Applications - Installation



Made in Germany 



Table of content

I. Hard Water and the Scale and Rust Problem

1. The Scale and Rust Problem	
1.1 What is Limescale?.....	2
1.2 The Formation of Scale	2
1.2.1 Changes of water pressure	2
1.2.2 Increase of water temperature.....	2
1.3 Problems caused by Scale and Rust.....	3
1.3.1 Rust - the common problem with scale	3
1.3.2 Bacterial growth - the side effect of scale.....	3

II. Vulcan - Information and Technology

2. Vulcan - Your Electronic Anti-Scale System	
2.1 Quick Info.....	4
2.2 The Vulcan full Acrylic Cast.....	4
2.3 The Vulcan Impulse Bands.....	5
2.4 Quality Indicators - 12 Reasons why Vulcan is so good	6
2.5 German Quality Certifications.....	7
3. The Vulcan Technology	
3.1 Electronic Scale Protection - The 3 Vulcan Effects.....	8
3.1.1 1 st Vulcan effect - Vulcan stops scaling in pipes and appliances.....	8
3.1.2 2 nd Vulcan effect - Vulcan gently sanitizes the piping system.....	8
- The removal of scale = the removal of rust.....	9
- The removal of scale = the removal of bacteria.....	9
3.1.3 3 rd Vulcan effect - Vulcan protects against rust damage and perforation	9
3.2 Physical water treatment - How it works	10
3.2.1 The Vulcan impulse field	10
3.2.2 Two natural phenomena	10
a.) Separation of $\text{Ca}(\text{HCO}_3)_2$ by controlled electrophoresis	10
b.) Separation of $\text{Ca}(\text{HCO}_3)_2$ by Overtone treatment.....	11
4. External Factors and their influence on the Treatment	
4.1 The Time Factor.....	12
4.2 The Distance Factor.....	12
4.3 The Combination Factors: Temperature - Pressure - Type of heating	13



4.4	The Water Quality Factor	14
4.4.1	High concentration of iron (Fe).....	14
4.4.2	High concentration of manganese (Mn)	14
4.4.3	High concentration of salts - (Cl, PO, NO ₃ , SO ₄)	14
4.4.4	Very high concentration of calcium	14
4.4.5	Swimming pool water	15

5. Product Comparison

5.1	Vulcan vs. Water Softeners	16
5.2	Vulcan vs. Magnetic Systems	17

III. Application Areas

6. Private Applications: Vulcan in your Home

6.1	The benefits in your private home – Protection for the piping system	20
6.2	Kitchens, kitchen appliances, bathrooms	20
6.3	Gardening and Irrigation	20
6.4	A healthier Lifestyle	21
6.5	Swimming Pools and Jacuzzis.....	21
6.6	Heating and Solar Water Heating	21
6.7	Vulcan and Reverse Osmosis Filters	22
6.8	Vulcan and Water Softeners.....	22
6.9	Vulcan and Well / Bore-wells.....	22
6.10	Saving Money with Vulcan	23

7. Commercial and Industrial Applications

7.1	Condominiums and Large Buildings.....	24
7.2	Educational Institutions.....	25
7.3	Public Swimming Pools and Jacuzzis	26
7.4	Hospitality: Hotels, Restaurants, Cafés	27
7.5	Medical: Hospitals, Nursing Homes, Residences.....	28
7.6	Agriculture: Plants, Livestock, Machinery.....	29
7.7	Industrial Applications.....	30
7.8	Maritime Applications	31
7.9	Farming Applications	32
7.10	Poultry Applications	33

8. Commercial and Industrial Applications: Benefits

8.1	Facility Management.....	34
8.2	The Piping System.....	34



8.3	Technical Appliances	34
	- Heating	34
	- Solar water heating	34
	- Cooling towers	34
8.4	Vulcan in Hotels and Restaurants	34
	- Cleaner bathrooms and kitchens.....	34
	- Dishwashers, laundry and washing machines	35
	- Grease traps	35
	- Gardening and irrigation	35
	- Reverse osmosis system (RO)	35
	- Swimming pools, jacuzzis, spa and wellness.....	35
8.5	A healthier Lifestyle	35

9. Commercial and Industrial Applications: Savings Potential

9.1	Monthly Savings in Large Buildings	36
9.2	Increase the Efficiency of the Heating System	36
9.3	Your Hotel Operations – Some Cost Saving Factors	36
9.4	Throw out that expensive Water Softener	37
9.5	Savings in Machinery Operations	37

10. Vulcan and its Effect on Machinery and Equipment

10.1	Heating and Heat Exchangers	38
	- Background knowledge on water heating systems	38
10.2	Grease Traps	39
10.3	Ice Machines	39
10.4	Solar Water Heating	40
10.5	Snow Production	41
10.6	Cooling Towers	42
10.7	Reverse Osmosis Systems (RO)	43
10.8	Vulcan and Water Softeners	43
10.9	Saving Potential in Machinery Operation	44

IV. Installation and FAQs

11. Vulcan Installation

11.1	Choosing the right Vulcan Size	45
	11.1.1 The pipe diameter.....	45
	11.1.2 The water capacity.....	46



11.2	Choosing the right Installation Location	47
11.2.1	Installation in a private house	47
11.2.2	Installation in apartment buildings.....	47
11.2.3	Installation in commercial & industrial settings	47
11.2.4	Installation in circulation lines	47
11.3	Factors influencing the Installation Location	48
11.3.1	Electric power fields or magnetic fields	48
11.3.2	Position of pumps and filters.....	48
11.3.3	Piping conditions of the installation area	48
11.3.4	Outdoor installation.....	49
11.4	Quick Guide: Do-It-Yourself Installation	50
11.4.1	Notes on the installation and examples.....	50
11.4.2	General information.....	50
11.4.3	Installation instructions for the Private Line.....	50
11.4.4	Installation instructions for the Commercial and Industrial Line.....	51
11.4.5	Technical drawings	52
	Solar water heating, solar pool heating and filtration, cooling towers	52
12.	Setting the Vulcan Programs	
12.1	Commercial Line - Vulcan S10, Vulcan S25, Vulcan S100	53
12.2	Industrial Line - Vulcan S250 and Vulcan S500	53
13.	Vulcan - Installation check List	54
14.	FAQs	
14.1	The Piping System.....	55
14.2	The Water Quality	56
14.3	Installation and Operation	56
14.4	Miscellaneous	57
14.5	Trouble Shooting	58

V. Appendix

15.	Water Hardness Classification.....	59
16.	Technical Data Overview	60

Introduction

Physical water treatment has over the years successfully proven to be an efficient method to improve the quality of our water without adding chemicals or salt. Nowadays, it has become even more important to capitalize on technologies which do not harm our environment but rather try to create an optimal balance between man and nature.

Vulcan is based on such a technology and is the result of over thirty years of constant research and improvements in the field of physical water treatment by Christiani Wassertechnik GmbH (CWT). Our latest product generation continues to provide you with reliable German quality combined with an extensive warranty.



Christiani Wassertechnik GmbH (CWT)
 Köpenicker Str. 154
 10997 Berlin
 Germany

From USA/Canada

Phone: +1 (719) 300 - 0494
 E-Mail: jc@cwt-international.com
 Web: www.vulcan-descaler.com

From other countries

Phone: +49 (0)30 - 23 60 77 80
 Fax: +49 (0)30 - 23 60 77 810
 E-Mail: sales@cwt-international.com
 Web: www.cwt-international.com

© 2011-2012 Copyright

Permission is granted to copy or print material published in this book, for personal use only. Its use for any other purpose, and in particular its commercial use or distribution, are strictly forbidden in the absence of prior written approval.

Any content is not allowed to be translated into other languages. It is not allowed to detach the binding or pages from the book. It is also forbidden to add pages. Please address your requests for approval to the above address.



I. Hard Water and the Scale and Rust Problem

1. The Scale and Rust Problem

1.1 What is Limescale?

Scale mainly consists of calcium and magnesium - two minerals that by themselves have a healthy effect on the human body. However, what is good for living organisms quickly becomes a scale problem as it deposits in the piping system, in machinery or on surfaces outside the piping system. So-called hard water holds high concentrations of calcium: the more calcium in the water, the harder the water and more problems.



1.2 The Formation of Scale

Scale builds up whenever hard water flows through a pipe. Liquid calcium in untreated water crystallizes into a sticky structure (pic. 1). These crystals adhere to each other, adhere to surfaces and immediately produce solid scale deposits that have a very destructive effect.



pic. 1

1.2.1 Changes of water pressure

Scale grows in particular when the water pressure changes. This happens when water changes direction in a bend or intersection which then causes turbulence; or when it leaves the piping system through a faucet. This drop in pressure enhances the formation of calcium crystals, which form a sticky structure that deposits anywhere.



1.2.2 Increase of water temperature

Scale also particularly forms when the water temperature inside the system increases such as on heating elements or in radiators. The hotter the surfaces, the more scale problems will develop. These problems can specifically be found on heating elements, with water heaters and heat exchangers.

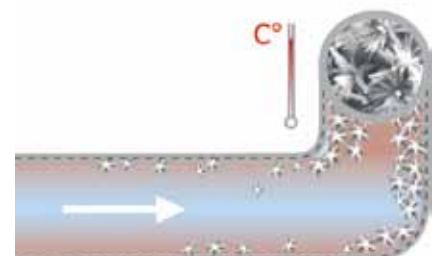

1.3 Problems caused by Scale and Rust

- Blocked piping system
- Loss of water pressure due to a reduced pipe diameter
- Rust accumulation in the pipes that may lead to corrosion
- Bacterial growth in drinking water carrying pipes
- Repeated repairs or replacement of household appliances
- Replacement of the whole piping system
- Loss of energy in the hot water circuit and high costs for heating
- Dull surfaces in bathroom and kitchen
- High cleaning costs and the need of aggressive cleaning agents
- Malfunctioning machinery
- High production costs due to maintenance
- Long pauses in production when machinery has to be maintained and cleaned leading to inefficient production planning
- Decrease in productivity



1.3.1 Rust - the common problem with scale

Unfortunately, scale deposits also attract other unwanted substances which again create even more problems and threats: The main components of scale are calcium and magnesium. This would lead us to believe that scale deposits have a white color. However, most scale deposits are brown. As soon as scale deposits built up, all iron and oxidized iron particles imbed into the scale. This also means that rust is firmly attached to the pipe which causes a serious threat to the pipe by pitting corrosion.

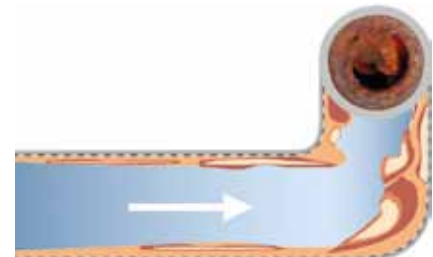

1.3.2 Bacterial growth - the side effect of scale

Scale deposits are also perfect breeding ground for bacteria and other unwanted micro-organisms. As the deposits have an uneven, rough surface, these little sockets are a perfect hide-out for bacteria to nest in. Whether in cold or hot water, you will always face an increase in potentially dangerous bacteria growth on the scale.

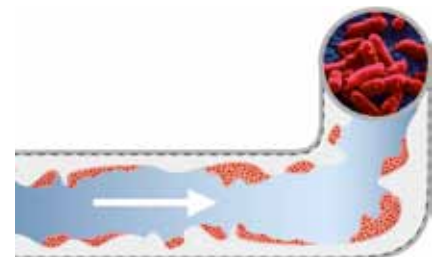

Water heater



Heat exchanger



Washing machine heating element



Pipe with scale deposits



Tube heat exchanger



Plate heat exchanger

II. Vulcan - Information and Technology

2. Vulcan - Your Electronic Anti-Scale System

2.1 Quick Info



The salt-free alternative to water softeners

Vulcan is an eco-friendly water treatment system that protects your piping system and appliances against scale deposits and rust. The **Vulcan-Impulse-Technology** is based on the principle of physical water treatment. Special electronic impulses change the crystallization process of the liquid calcium. This way the hard scale loses its adhesive power. The technology works exclusively with capacitive electric impulses: no use of any salt or chemicals.

- The eco-friendly solution against scale problems
- No use of salt or chemicals
- Suitable for pipe diameters from 1/2" to 20" (~10-500 mm)
- Fully cast in acrylic for optimal quality endurance
- Do-it-Yourself installation without cutting the pipes
- Works on every pipe material – iron, inox, copper, stainless steel, galvanized iron, plastic, PVC, PE-x, hose, compound pipes (any material mixture), etc.

2.2 The Vulcan full Acrylic Cast

The special Vulcan acrylic cast guarantees the best quality. Vulcan is especially designed for use in humid, wet, very cold or very hot areas.

The acrylic cast ensures that the **circuit board is protected**. The parts are fully covered in acrylic. Therefore the parts can not move and are fixed in place. This guarantees a high life expectancy.

It **protects the unit from humidity**, e.g. when installed outdoor. The full body acrylic cast protects from dust and dirt, e.g. when installed in a basement.

The full body acrylic cast **protects against heat and coldness** as acrylic is a perfect isolating material. E.g. when installed in extremely hot areas with outdoor temperature up to 45-50°C (~113 - 122 °F) or in very cold temperatures down to -25°C (~-13°F).



The acrylic cast ensures a very long product life. The Vulcan's solid acrylic **isolating material** ensures that the electronic components are perfectly isolated from the inside as well. The most common cause of a malfunction in electronic devices is a burn-out on the circuit board due to excessively high operating temperatures. The thick acrylic covering together with the **vacuum prevents heat production**. This "cooling" of the unit ensures a long life.

2.3 The Vulcan Impulse Bands

Vulcan operates with customized isolated copper impulse bands that are designed to firmly connect to the pipe. They are extremely thin and flexible with minimized isolation. This way, they achieve minimal spacing loss and maximize the direct-contact-ratio to 97.5%. Their special copper material with a high alloy purity degree guarantees the best possible transfer output. The copper treatment bands are a crucial factor to the performance of the water treatment.



The pipe diameter / treatment area ratio

The impulse bands cover the surface area that is vital for the treatment. The surface of the pipe that is covered by the impulse band is the "treatment area". This area needs to be large enough to ensure that the impulses are transmitted through the pipe. As a general rule each impulse band should cover a treatment area of at least the length of the individual pipe diameter where Vulcan is to be installed:

Treatment with round cables vs. impulse bands

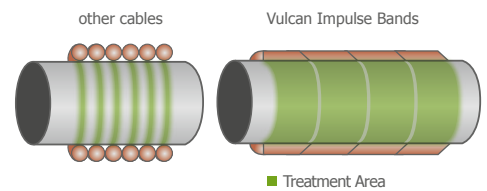

Comparison: The Vulcan Impulse Bands accumulate more direct contact compared to round cables as there is less spacing. The direct contact ratio reaches 97.5%.

Example

If you install a Vulcan 5000 on a 2" pipe, each impulse band should cover a pipe length of min. 2".

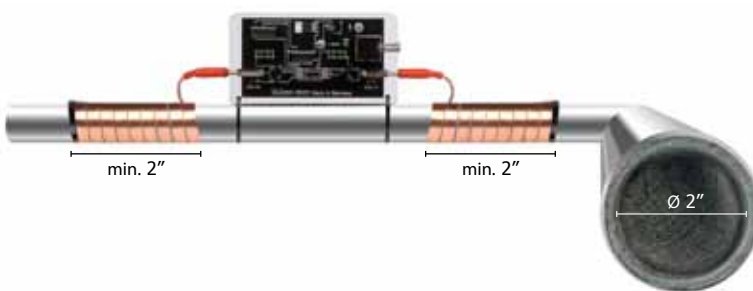

2.4 Quality Indicators - 12 Reasons why Vulcan is so good

Vulcan clearly stands out with its quality and performance.

Please compare Vulcan against other products by matching some quality indicators:



German 24 Volt Impulse-Technology

(capacitive): The water is treated with electric impulses that control scale in an eco-friendly "green" way. It is an electric system that is not magnetic-based.



Vulcan works on a **frequency range**

between 3-32 kHz with different frequency peaks (wobbling distribution). The secret to the right performance of physical water treatment lies in the composition of these impulses. CWT has developed and fine-tuned them for over 30 years.



Vulcan uses **customized isolated copper**

impulse bands. How the impulses are transferred into the water is crucial. The design of the bands increases the surface area that transports the impulses. This improves transmission by up to 40%.



The **original acrylic cast** is unique to the

Vulcan product line. It offers maximum protection against water, heat, dirt, coldness, humidity and keeps all parts secure and sealed in place.



Vulcan comes with external **UL and TÜV-**

approved electronic switching adaptors. They operate with a very low power consumption of 100-240V and equalize possible power instability.



Vulcan is not magnetic-based. Therefore,

it operates **100% independent of the velocity** (water flow rate) in the pipe and constantly provides reliable impulses that guarantee the right output at all times.



Material-matching programs for different

materials: Vulcan treats any pipe material. No need to buy a different product for metal, PVC, plastic etc. any more.



The **automatic memory** program keeps

Vulcan running correctly. In case of the unlikely event of a power failure Vulcan automatically resets back to the last program once power is regained.



Vulcan holds numerous **certifications**

by renowned international institutions: the German TÜV, the German CE, the UL approval (USA/Canada) for switching adaptors etc.



Vulcan requires very little electrical power as

it is **very economical.** The units operate with 1.75 to max. 3.25 Watt. The running costs are approx. \$ US 3-7 (~3-6 EUR) per year.



Made-in-Germany: Vulcan is a **German**

quality product that has been manufactured by the family-run Christiani Wassertechnik GmbH, Berlin since 1989.



10-year international warranty is

granted for all Vulcan units. Due to the special acrylic protection these units keep on running with a life expectancy of over 30 years.

2.5 German Quality Certifications



The German TÜV/GS is an independent institution that assesses products for safety and reliability. When a product passes the strict regulations it is awarded the TÜV/GS mark which indicates that the product was tested and certified for safety according to the "German Equipment Safety Law". The GS mark is a certification that includes periodic factory inspections covering the quality system for the production. This law requires inspectors to frequently assess whether the manufacturer is able to maintain all the specifications of the tested product in his production. During this factory inspection, the implementation of the quality system, the production environment, and production related testing and measurement equipment is evaluated.



CE Approval

The CE mark certifies that a product has met German and European Union consumer safety, health or environmental requirements. "CWT hereby declares that this product is operating in accordance with the following EU guidelines: 73/23/EG; 89/336/EG which is certified by the CE-mark. The equipment corresponds to the requirements of the German Industrial Safety Act and the European low-voltage guidelines."



Certificate of Origin Germany

The Certificate of Origin (CO) names and officially approves the country where the goods are actually produced. For Germany the certificate is issued by the German Chamber of Commerce (IHK). It approves the German origin (Made in Germany) after thorough investigation of the origin of each individual part of the product and after assessment of the production site in Germany.



UL Approval (USA/Canada)

The UL - Underwriters Laboratories Inc. is an international quality and safety approval institution with headquarters in Illinois, USA. The UL-mark on a product states that UL has tested and evaluated the product and determined that the electronics fulfill the strict safety guidelines. All Vulcan switching power adaptors are meeting these requirements and comply with international standards.

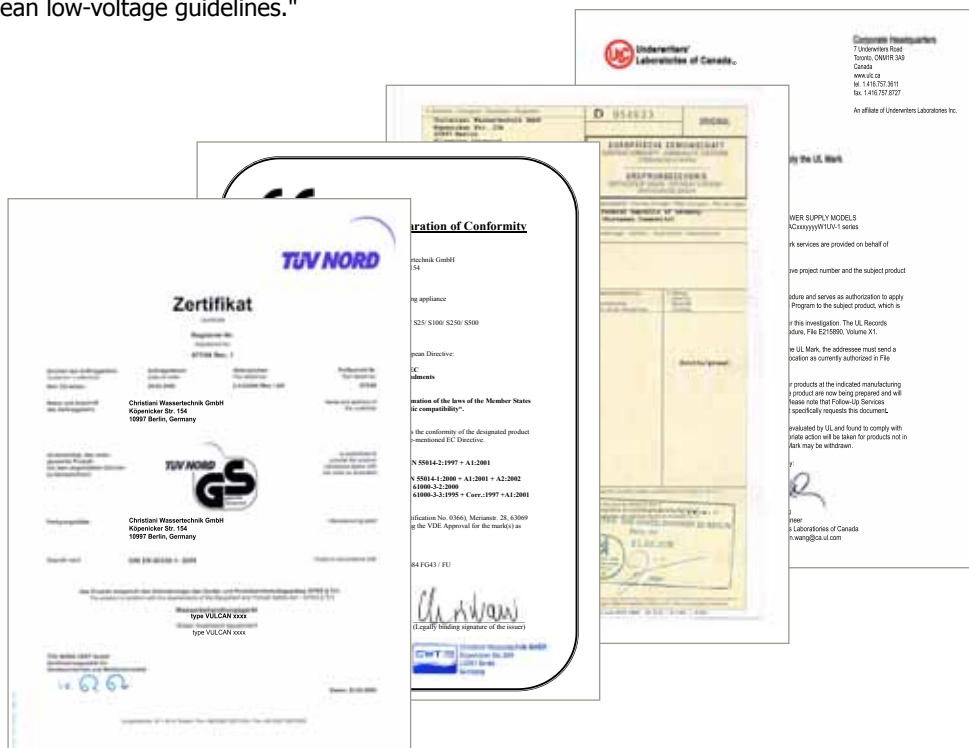

3. The Vulcan Technology

3.1 Electronic Scale Protection - The 3 Vulcan Effects

3.1.1 1st Vulcan effect

Vulcan stops scaling in pipes and appliances

Without the Vulcan water treatment, the scale particles in the water form sticky crystals that then build solid deposits. The patented Vulcan-Impulse-Technology modifies the crystallization of calcium and magnesium using the natural process of electrophoresis. The crystals become smoother and rod-shaped and can no longer attach to each other. Scale is now washed away in the water as a fine powder. The formation of new deposits is stopped. The more of the rod-shaped crystals that are created, the stronger the positive effect of scale-prevention.

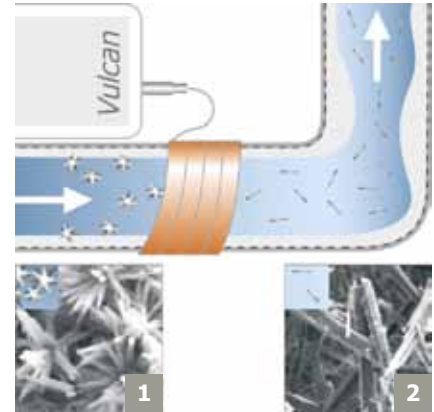

Mono crystals as a result of the Vulcan water treatment

When mono-crystals are created by the impulse variation, it is important that they grow as long as possible before they start their way through the piping system. The larger the crystals, the longer it takes until the crystals fall apart again and eventually "die". In warm water, these crystals grow faster and therefore are stronger and live longer. This explains why the Vulcan-effect lasts the longest in warm water (up to seven days) and shorter in cold water (approx. two days).

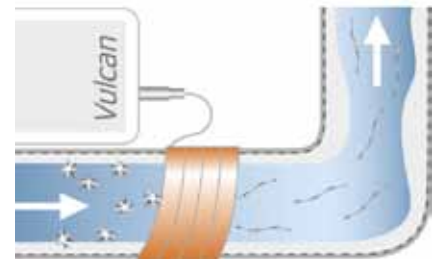

3.1.2 2nd Vulcan effect

Vulcan gently sanitizes the piping system

Two simultaneous processes take place in untreated, hard water:

- In the first process, scale deposits result from calcium crystals adhering to each other which then adhere to surfaces. This first process produces carbonic acid (H_2CO_3) as a side product.
- During a second process, the carbonic acid simultaneously breaks down the existing scale deposits. This is referred to as the "natural resolving process". Because the build-up process takes place much faster than the natural resolving process the pipes' diameter constantly decreases.

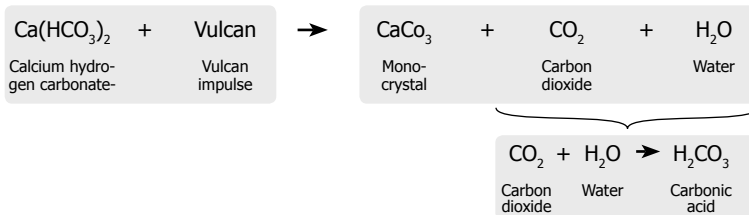

The Vulcan water treatment changes the balance between the scaling process and natural resolving process. The mono-crystals can no longer form deposits, therefore the scale build-up of the first process is reduced. The natural scale-resolving-process now needs only to deal with existing deposits and can effectively combat them. Thus scale is removed faster than it forms. The natural surplus of carbonic acid dissolves the scale from the scale. Gradually and carefully, the deposits in the pipes will be removed.

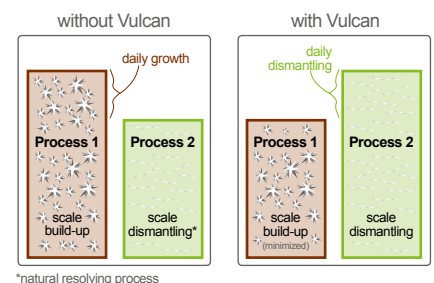

*natural resolving process

The removal of scale = the removal of rust

As soon as scale deposits have built up, iron particles imbed into it. Thus, the scale and the rust blend into one material that are seen as red-colored deposits in the pipe. When the Vulcan treatment dismantles the scale, it simultaneously removes all rust with it. Clearing out the deposits is a gentle process where scale is brought back into solution and washed out in the water as: calcium, magnesium and iron. It is absolutely safe to drink as these are all healthy minerals.

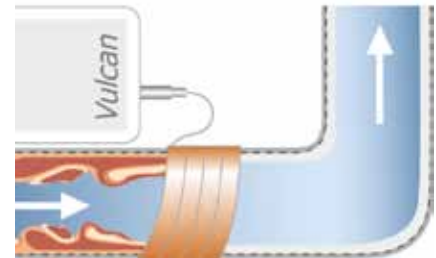

The removal of scale = the removal of bacteria

We know that scale acts as a breeding ground for bacteria and other unwanted substances. As soon as Vulcan is installed and the scale is cleaned away, the bacteria breeding ground disappears. This way, bacterial contamination is greatly reduced or even fully removed.

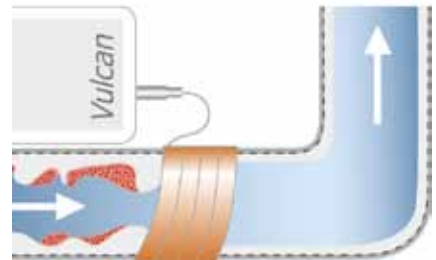

3.1.3 3rd Vulcan effect

Vulcan protects against rust damage and perforation

Copper and/or iron oxidation occurs in all metal pipes through contact with calciferous (hard) water. These oxides seriously affect the pipe surfaces and may lead to corrosion. The Vulcan-impulse-technology generates an electrophoresis effect which produces a protective metal-carbonate layer. According to the material of the pipe, this layer consists of copper carbonate, iron-carbonate or zinc-carbonate and settles on all shiny metal surfaces. It protects the pipe from aggressive substances which could lead to corrosion.

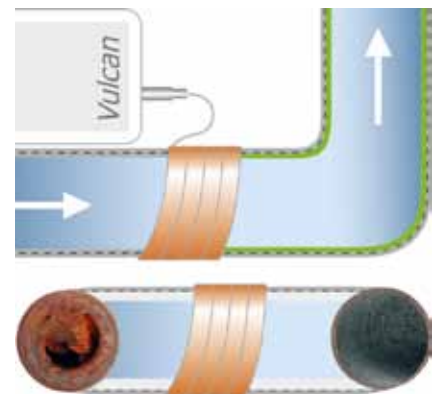

3.2 Physical Water Treatment - How it works

Vulcan is a physical water treatment system that does NOT use chemicals or salt. It does not change the chemical mixture of the water. Instead, it changes the physical characteristics of the scale crystals in a way that the scale particles lose their adhesive power. Vulcan does not need to have direct contact with the water and sits outside of the pipe.

It treats the water with electric impulses which are generated in the electronic unit and are controlled by a computerized microchip. The signal-frequencies are transmitted via the Vulcan impulse-bands that are wrapped around the pipe. The bands interact as pairs and form a frequency-field that treats the water as it flows by.



3.2.1 The Vulcan impulse field

The Vulcan impulse bands act as pairs with a right side and a left side. Each side triggers an alternating specific signal pattern which is sent ten times per second onto the pipe. The electronic impulse field is generated from frequencies between 3,000 and 32,000 Hz. Due to the alternation of the signal sides, which means that only one impulse band side is active at a time, the frequencies in the impulse field are overlapping. This effect multiplies the frequency patterns which again creates specific (harmonic) overtones.

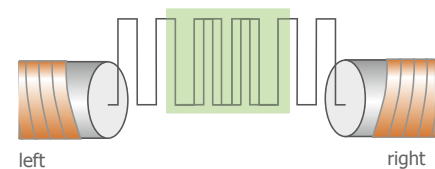

The Vulcan treatment is executed precisely, because the one-step impulse generation exactly generates the desired outcome. It is operating completely independent from the velocity (water flow rate) and as the electricity is provided from the power supply, allowing a continuous stream of impulse field generation.

3.2.2 Two natural phenomena

Scale deposits build up when the liquid calcium in the water forms crystals that stick together (pic. 1). Physical water treatment creates a different kind of calcium crystal structure that loses its power to attach to surfaces and build deposits. These harmless new **mono-crystals** (pic. 2) **are the key players in the Vulcan water treatment.** Vulcan generates various processes to produce these mono-crystals and sanitize the piping system:

a) Separation of $\text{Ca}(\text{HCO}_3)_2$ by controlled electrophoresis

The alternating frequencies in the impulse field create an electronic gradient that manifests the electric potential in the water. This potential influences the liquid calcium $[\text{Ca}(\text{HCO}_3)_2]$ and separates its individual parts.



1. Untreated crystals



2. Mono-crystals (CaCO_3)

Separation of $\text{Ca}(\text{HCO}_3)_2$

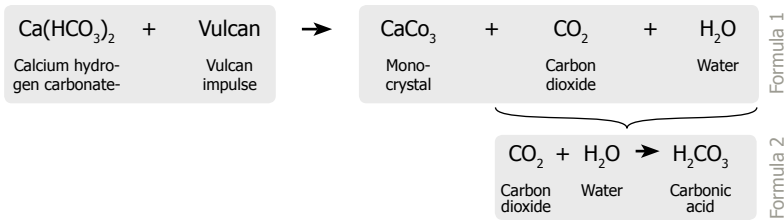

This is the birth of the calcium mono-crystal, which can only grow into two opposite directions and can therefore not cluster together with other mono-crystals to form scale deposits. The mono-calcium-crystal forms in a rod shape (pic. 3) between one end (+) and the other end (-). In this form they can no longer stick together and forms deposits. During its journey in the pipe system it will grow in size. The longer the mono-crystal, the better the effect of the treatment.

The separation of the water components due to the electrophoresis also changes the balance of calcium and carbonic acid, which creates a slight surplus of carbonic acid (formula 2). This small rise in free carbonic acid helps the cleaning of already existing scale deposits.

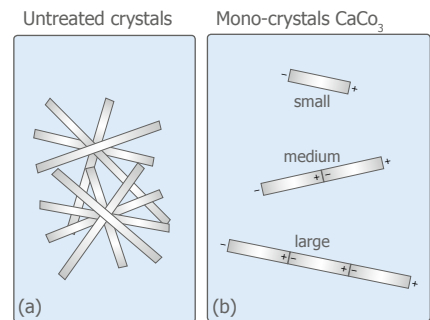

pic. 3

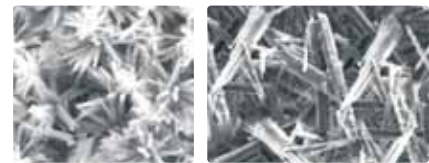

As opposed to the typically chaotic clustered calcium-crystal (a), the treated crystal forms as well ordered mono-crystal (b) (the so called aragonit shape) that is stream-lined between the one end (+) and the other end (-).

b) Separation of $\text{Ca}(\text{HCO}_3)_2$ by overtone treatment

The Vulcan impulse treatment controls the creation of overtones as a result of overlapping frequencies. The overtones are set to meet the characteristics of a water cluster which is basically the smallest entity of water. The extreme short wave lengths of the overtone parallels that of the water cluster to the extent that the two begin resonating with each other. Just as a high-pitch tone can burst a wine glass if it resonates with the glass, matching the wave-length of the overtone with the water cluster achieves the same result: the water cluster bursts.

When a water cluster bursts the same process of separation of the $\text{Ca}(\text{HCO}_3)_2$ components happens (compare formula 1). The stronger this effect, the more the mono-crystals grow, which results in the desired effect of scale and rust dismantling.

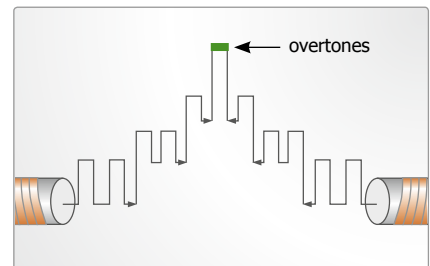

→ Mono-crystals and carbonic acid

Both the controlled electrophoresis (a.) and the overtone-treatment (b.) result in separating the liquid calcium $[\text{Ca}(\text{CO}_3)_2]$ into its individual substances. This way, Vulcan generates the rare mono-crystals and a higher level of carbonic acid.

- The mono-crystals stop scale building up on surfaces
- Carbonic acid is the key ingredient to dismantling already existing scale deposits.

4. External Factors and their Influence on the Treatment

As the eco-friendly technology of physical water treatment operates within the laws of nature, we have to consider some of these laws. It is important for the Vulcan water treatment to create as many of the mono-crystals as possible. However, the mono-crystal structure does not last forever. From the moment of its creation, it has only a limited life expectancy. Time, distance and temperature determine how long the crystal will last and this again determines how long the effect will last.

4.1 The Time Factor

The effect of the Vulcan lasts a minimum time span of 48h in cold water and up to 7 days in warm water.

- In warm water (= more than 30°C/ 86°F) the effect lasts up to 7 days
- In cold water (= below 30°C/ 86°F) the effect lasts up to 2 days

Why does the temperature have an effect on how long the Vulcan effect is active?

When mono-crystals are created by the impulse variation, it is important that they grow as long as possible before they start their way through the piping system. The larger the crystals, the longer it takes until they fall apart again.

It is well known in nature that **heat** speeds up the growth process. It is the same with the mono-crystals. In **warm water**, the crystals grow faster and longer than in cold water. This results in a much higher number of crystals, together with a larger size of the individual crystals. The larger crystals then survive up to 7 days.

Cold water does not promote the crystal's growth as much and they are usually smaller. However, in cold water the scale deposits are usually less prominent. In the cold-water setting the effect lasts up to 2 days.

4.2 The Distance Factor

We know that the mono-crystals do not last forever. The travelled distance has an effect on the crystal's life expectancy. When they begin their journey through the piping system they fall apart during that time.

Several factors such as complexity of the piping, the number of intersections and divisions, variations of pipe diameters throughout the piping system or the existence of pumps all have some influence on the crystal's life. For example, passing through turbulence in a bend promotes the growth of a mono-crystal and will help to extend its life.



Experience shows that the Vulcan effect will start to diminish after a distance of approximately 2.000 m (~ 1.2 miles) in the pipe. However, long distances of 2 km (~ 1.2 miles) or more are rarely reached within buildings. Furthermore, with the favorable pipe system setup, the effect often last longer.



4.3 The Combination Factors: Temperature - Pressure - Type of heating

a. Temperature and its effect on the treatment

The water temperature itself is one factor that has some influence on the duration of the treatment (how long the effect will last). We learned that warm water (30°C/86°F or more) has a positive effect on the growth of the mono-crystals (see section 4.1) and therefore is even supporting the treatment.

Extreme heat such as a heating element surface temperature of above 95°C (203°F) may also influence the treatment's outcome. What we observe with the scale situation of a heating element is that the heating element stays cleaner at 98°C (208°F) surface temperatures than at 110°C (230°F) or than at 130°C (266°F) and so on. This is a natural finding as heat promotes the scale formation. In general, the calcium crystals naturally want to gain back their common shape.

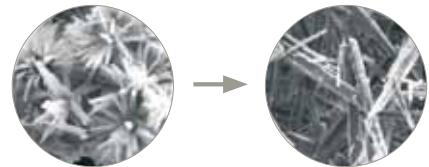

Combinations: A mixture of influences

The combination of several external factors together influence the treatment and it is not always possible to know the exact outcome in advance:

Temperature is one influence to consider. A second factor to keep an eye on is high pressure (e.g. in boilers/ steamers). What also comes into the equations is the way of the heating provided (gas, electrical, heat exchanging, burner etc).

▶ When there is extreme heat, a specific pressure with that and a heating technology involved, this mixture may have a somewhat different treatment effect.

Please consider that in such a situation it may be best to test and see.

For example, a typical finding can be: the hot surfaces of burners, heating elements or steam generators may show some more deposits from 95°C up. For example: the heating element stays cleaner at 98°C (208°F) surface temperatures than at 110°C (230°F) then at 130°C (266°F) and so on.

Conclusion

When several factors including extreme high heating element temperatures and high pressure together with one of several possibilities occur together, the treatment effect is not always easy to predict. Always put in a trial installation! When the customer understands these variables he knows what to expect and what not.

4.4 The Water Quality Factor

The individual composition of water and especially very high concentrations of certain substances can influence the Vulcan treatment.

4.4.1 High concentration of iron (Fe)

Iron is naturally found in water. Very high iron content is typically found in water wells which then often causes problems with rust. If the iron content reaches more than **1 mg/l (1 ppm)** it may have a negative effect on the treatment.

Treating the iron problem: We advise to treat any problems with very high iron content in the water with a de-ironing filter. This will ensure that the Vulcan treatment can reach its full potential.

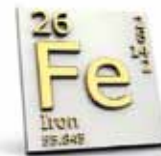

4.4.2 High concentration of manganese (Mn)

Manganese is naturally found in water. Very high manganese content is typically found in water wells which then often causes problems with rust. If the manganese content reaches more than **0,1 mg/l (0,1 ppm)** it may have a negative effect on the treatment.

Treating the manganese problem: We advise to treat any problems with very high manganese content in the water with a de-manganization filter. This will ensure that the Vulcan treatment can reach its full potential.



4.4.3 High concentration of salts - (Cl, PO, NO₃, SO₄)

Sea Water: Very salty water (e.g. sea water) usually does not lead to scale problems. In general, ocean water does not affect the performance of Vulcan and you will see good results.

Cooling towers: However, high concentration of „salt“ (all sorts of salts: Cl, PO, NO₃, SO₄) is a typical cooling tower issue. As cooling towers are half-open circuits with water constantly evaporating, the substances in the water constantly concentrate. Within a short time, the water hardness and the salt level may dramatically increase (e.g. Cl, PO, NO₃, SO₄). Here, it is recommended to use Vulcan with water that has a conductivity of 5000 µ-Siemens or more.

Cl= Chlorine, PO= Phosphate, NO₃= Nitrate, SO₄= Sulfate



4.4.4 Very high concentration of calcium (Ca)

The problems with scale deposits start when the water contains large amounts of calcium. Vulcan can be successfully applied to water having a very high to extreme high degrees of hardness. Vulcan has successfully treated cases with water hardness of 1000 ppm (~ 59 gpg) or more).

Typical extreme-high hardness degrees occur in cooling towers. Here, even when the conductivity is extremely high (e.g. 5000 µ-Siemens* or more) Vulcan will show great results. Basically, the harder the water, the more obvious the results. *Conductivity in cooling towers is measured in micro-siemens which is an indicator but does not give exact hardness degrees.

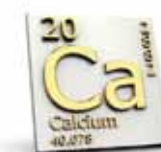

4.4.5 Swimming pool water

There are no typical limit values to substances in pool water that are known to hinder the Vulcan water treatment.

However, the water in a swimming pool demands constant monitoring and several chemicals need to be added. Vulcan significantly reduces the scaling in and around the swimming pool, in the whole piping system and in the filters and pumps. Therefore, once Vulcan is installed, chemicals can usually be reduced:

Disinfection

Chlorine: The disinfection of pool water is mostly secured by adding chlorine (Cl). Products range from granules to liquids, tabs or sticks. The addition of chlorine can often be reduced by up to 10-25 percent. Please cut back step by step (e.g. start with a reduction of 10% and then raise it).

Active oxygen is used as chlorine-free disinfection alternative. The amount can also often be reduced. Please apply the step by step reduction.

pH adjustor products either reduce or raise the pH-level and control the total alkalinity in pool water. This is added in order to rebalance the pH which has been disturbed by the addition of chlorine/oxygen. In line with this, the use of adjustor products can be reduced in the same ratio to which the disinfectant product has been reduced. E.g. if you reduce chlorine by 15% you can usually also reduce the pH-adjustor by 15%.

Pool cleaning

Pool cleaning agents are used to fight scaling on the waterline, in grids, on tiles or the pool's surrounding surfaces. The Vulcan water treatment minimizes scaling which results in a much easier cleaning process together with a reduction of cleaning agents/chemicals by up to 50%.



5. Product Comparison

5.1 Vulcan vs. Water Softeners

Vulcan is an electronic (capacitive) impulse based, eco-friendly water treatment system that solves your problems with scale and rust. However, there are other units available that are based on other principles.

Salt-based water softeners (so-called ion-exchangers) are using salt and chemicals to treat the water. They are installed into the piping system which should only be done by a professional plumber. They exchange the minerals (calcium and magnesium ions) with twice as much sodium (salt) ions. As calcium and magnesium gets deleted, the water is softer afterwards. This way softeners considerably increase the sodium content of the water which can cause considerable health threats and certainly is a threat for the environment.

Burning money: Regular water softeners are not only expensive to purchase but also you will need a specialist to do the installation. Once in place you will have to constantly refill it with salt. Never-ending maintenance: Maintenance includes the constant refilling with salt, the washing of the granule and the checking of valves and measuring station.

Wasting resources: softeners require large amounts of salt and huge amounts of additional water of up to 30-80 gallons per wash (~110-300 l) to operate.

Water softeners need a lot of manpower as they constantly need to be fine-tuned and controlled. Especially season-related changes of the water quality (summer/ winter) are often simply forgotten to consider for the programming. The human error factor then prevents the unit from performing correctly.

Health issues: Babies, children, elderly people, people with salt restricted diets or anyone who is health-conscious should consult a physician regarding the sodium intake increase when using a water softener. The water loses its natural taste and may even taste salty. Also you may have to supplement the important minerals calcium and magnesium in your daily diet.

It is important to note that many of the water softeners have a bypass feature that will allow you to bypass the cold water in the kitchen. This will enable you to use unsoftened water for drinking and cooking. In addition, bypassing the cold water tap in the kitchen will prevent minerals from being removed from the water. However, then only part of your pipes are protected.

Water softeners make your water softer. But

... is that always a good idea?

... is it necessary to have extremely soft water?

*The answers are simple: **No and No.***

Hard water is a real nightmare as long as the scale builds deposits. The minerals calcium and magnesium in itself are good substances. Once you minimize the adhesiveness of the scale, it no longer bothers you as deposits but you can benefit from the healthy minerals. Very soft water is also not recommended for pipes as it might damage them (the soft water is too acidic).

Legislation and the Environment

The environment

Water resources are a valuable good. We require large amounts of fresh water but only 2.5% of the Earth's water is fresh, and over two thirds of that is frozen in glaciers and ice caps. The use of water softeners contributes to a decrease in the available fresh water on our planet. Therefore, it is important to use eco-friendly technologies and stop harming the environment.

The US government has started to put a ban on water softeners

For the above mentioned reasons and mainly due to the great threat to the environment, the US government has started to ban softeners.

5.2 Vulcan vs. Magnetic Systems

Vulcan is NOT a Magnetic System



Vulcan works exclusively with electric impulses only. The energy is simply taken from a power plug. We would like to distance ourselves from those devices that use the force of magnetism to treat water.

Why you should avoid magnetism when treating water

All magnetic-based physical water treatment devices produce electric impulses by induction. This means that the magnet(ism) together with the water that flows through the pipe are supposed to generate complex electric impulses, this sometimes gets achieved. However, the following problems cannot be ignored:

Problem with Magnetism: not all pipe materials can be treated equally good

As the magnet does not penetrate through metal very well, many distributors ask to install their units on plastic pipes. If the installation place is a metal pipe their recommendation is to cut out a piece of pipe and to replace it with a piece of plastic pipe.

► *We believe that this is an unnecessary complication to work with magnetism as it limits the treatment to take place on plastic pipes only.*

Problem with Magnetism: Magnetism itself

Magnetism is a powerful force indeed. It is attributed with many positive effects on organisms. However, everyone also knows that magnets attract metallic objects, no matter how small. This again leads to a major problem when magnets are used on a piping system because the area where electromagnetic cables or permanent-magnets are installed is of course magnetic. Here, all magnetic particles in the water are firmly connected to the inside of the pipe. This happens on metal and plastic pipes alike. After only a short while the inside of the pipe is covered with a metal-dirt-particle-film that is a perfect breeding ground (biofilm) for bacteria or other unwanted substances. Many producers of magnetic devices therefore suggest to turn off the unit and "flush" the pipes every six months as a solution to the problem.

► *We believe that building up a potential dangerous biofilm with magnetism in order to treat the piping system is not a smart way to solve the scale-problem. Also, we know the need to clean the pipe with flushing or brushing can be avoided. The answer is not to use magnetism.*

Problem with Magnetism: Velocity

The generation of a complex electric impulse field only works if the water inside the pipe flows by the magnetic field in the exact right speed (velocity).

If the speed is right, then the impulse is generated. However, if the speed of the water is not right (too fast or too slow), the impulses are not generated or -worse- the impulses are generated wrong.

► *We believe that it is the best to always provide the perfect and stable electric impulse field simply by using constant electricity. Therefore, Vulcan is solely electric. The annual power consumption is minimal and amounts to approx. 3-6€ (~ 5-7 USD).*

Differentiation

At first sight, an electromagnetic unit may look similar in principle. However, Vulcan operates differently: it works with an electronic control unit that produces the impulse signals. These signals are transferred onto the impulse bands which are connected to the acrylic electronic control unit.

In comparison, most electromagnetic units also have some sort of plastic box from which there are some cables emerging. The electronics in the box produce electricity which runs in the electric cables and come back *in a loop*. You will easily recognize that the cables run back into the box. This way, the cable acts as an electromagnet. Again, the Vulcan-impulse-bands do not run back, but end on the pipe.



Vulcan offers you a reliable eco-friendly water treatment system against scale and rust – without the drawbacks of magnetism.

III. Application Areas

6. Private Applications: Vulcan in your Home

Water treatment: Private houses and villas

Vulcan is your electronic anti-scale system that treats hard water without the use of salt or chemicals



Water is a valuable resource. However, hard water contains dissolved scale which will eventually build deposits in your pipes and appliances. Every house owner should use an eco-friendly water treatment in order to ensure that the piping system stays clean. This preserves the value of your home today and for the next generation to come.

The Vulcan-Impulse-Technology treats the water with special electronic impulses that take away the adhesive power of the scale particles. Scale components are simply washed away with the water as a fine powder. Vulcan also carefully dissolves already existing deposits. The build-up process is reversed and the piping system is clean once again. In addition, pipes consisting of metal often suffer from corrosion. The electronic Vulcan impulses generate a metal-carbonate protective layer that prevents pitting corrosion.

Benefits of using Vulcan

- ▶ Secure reduction of scale deposits in the whole piping system
- ▶ Less time and effort on maintenance in your home, and for household appliances
- ▶ Filters, shower heads and basins stay cleaner
- ▶ Faster cleaning of kitchens and bathrooms
- ▶ Considerable savings on cleaning agents
- ▶ Important minerals remain in the water
- ▶ Food and beverages keep their natural taste
- ▶ Cleaner sprinkler nozzles for garden irrigation
- ▶ Easier swimming pool maintenance



The eco-friendly alternative to water softeners

Treating hard water can be done in two ways.

Water softeners remove calcium and magnesium by adding salt ions, which drastically increases sodium in your drinking water. The problem with softeners are not only that they tamper with good water quality by adding salt. They also need a lot of maintenance and constant refilling of the salt tablets together with accurate settings.

Instead, **Vulcan** is maintenance-free and does *not* change the water composition. It leaves calcium and magnesium in the water which are important minerals for the body.

Installation

Vulcan is a **Do-It-Yourself** product and is easily installed within a few minutes without the need to cut pipes. You do not need any tools.

Please place Vulcan at the main water supply – this is usually close to the water meter. Vulcan is suitable for indoor and outdoor installation.

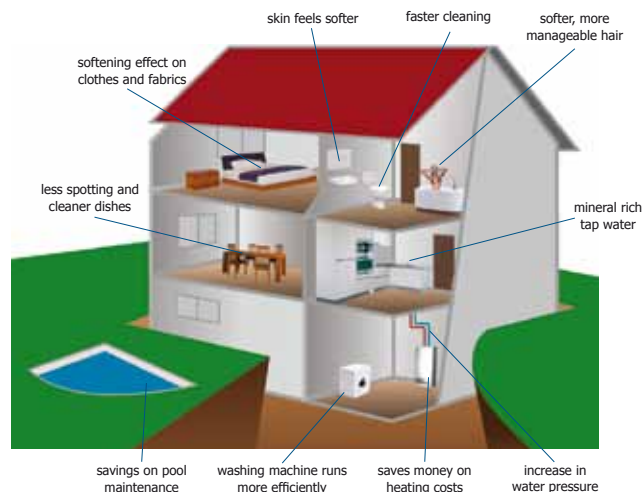

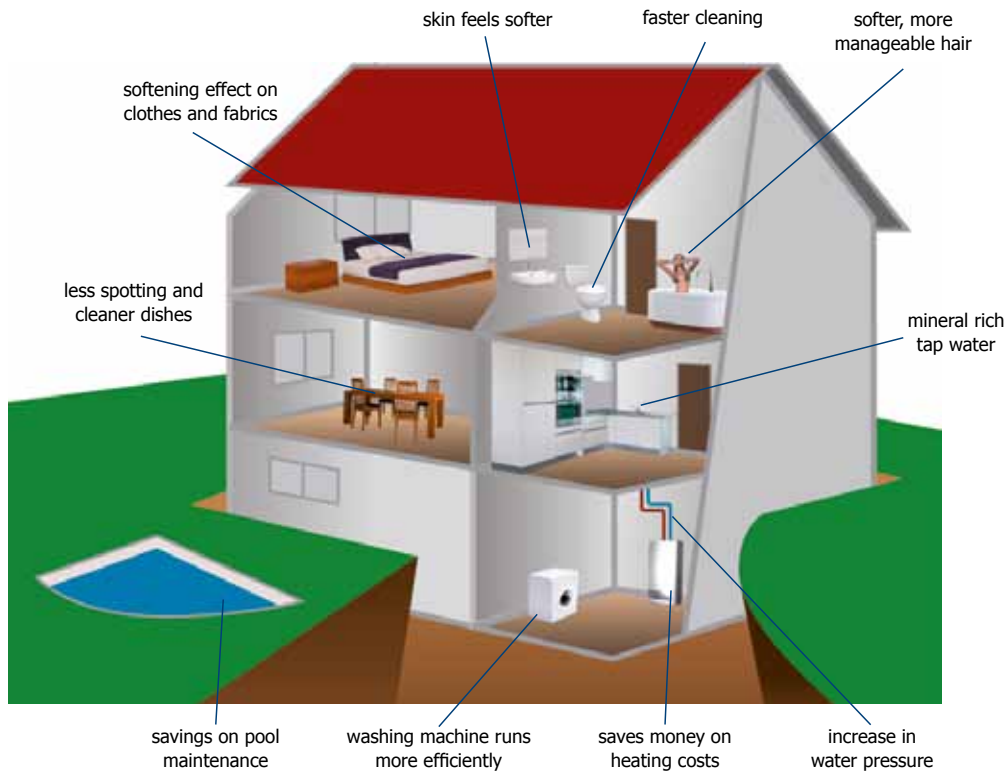

"We have after two weeks already found many of the statements in your product description to be impressively true. The inspection of the aerator after four weeks shows **no accumulation of scale**, in the past it was necessary to clean it every 4-6 weeks."



"On the first evening after the installation I was pleasantly surprised as I drank a glass of tap water. It has since then **tasted cleaner and milder.**"



"I was amazed to see the **positive difference**. I have noticed that my **hair feels softer** after washing it without using any additional hair cosmetics. Also the shower screen and the bathroom fixtures were **easier to clean** with much less cleaning agents."



"The device showed **effect one week after it was installed**. We replaced the filters in the bath fixtures during the installation of the device and since this time they **have remained free of scale**, as has the shower head."



6.1 The benefits in your private home - Protection for the piping system



a) Reduction of scale deposits in your piping system Vulcan takes away the adhesive power of scale particles so that scale is simply washed away with your water as a fine powder.

b) New scale-formation is stopped

Vulcan carefully dissolves already existing deposits in the piping system. The scale build-up process is reversed and the pipes gradually become clean again. This take-out process will not block up your pipes or drain because the treated crystals are microscopic in size and wash away in the water.

c) Corrosion protection

Metal pipes often suffer from pitting corrosion. The electric Vulcan impulses generate a metal-carbonate protective layer that prevents pitting corrosion.

d) Increased water pressure

Vulcan sanitizes the pipes from scale deposits and can even restore a pipe's full diameter. Water can flow freely again and you regain normal water pressure.

e) Vulcan minimizes rust

In most cases whenever there are scale deposits you will find rust shortly thereafter. The rust typically imbeds itself in the scale deposits. Because rust oxides are red, the scale deposits in metal pipes then often appear red in color, too. When the Vulcan treatment reduces scale, it also takes away rust with it.

f) Vulcan minimizes bacterial growth in pipes

Thick scale deposits with their uneven surfaces are the perfect breeding ground for bacteria. Once the scale is gone, there are no more nesting areas where bacteria can grow.

6.2 Kitchens, kitchen appliances, bathroom: Dishwashers, washing machines, bathrooms fittings, etc.

Kitchens and kitchen appliances

Kitchen surfaces, sinks, faucets and fixtures stay cleaner: You will quickly notice that scale is visible but acts like a fine 'dust' which can be removed easily with a damp cloth. Surfaces and tiles will be smoother and shinier again.

Dishwashers

Operate with less detergent and less additives. The use of detergent can be reduced by up to 25%. Typical spotting on dishware is reduced or no longer apparent.

Washing machines

Cleaning is more effective as Vulcan-treated water lathers noticeably more. The same amount of detergent will give you cleaner clothes. You can often reduce the amount of washing detergents in your daily use or stay away from very aggressive agents. Furthermore, Vulcan extends the life of the machine's heating element.

Bathrooms and well-being

Vulcan does not alter the chemical composition of water, and calcium and magnesium remain in the water. You will quickly notice that scale is visible but acts like a fine "dust" which can be removed easily with a damp cloth. Stains on basins, sinks, toilets or fixtures will be easily wiped away. Shower heads stay clean longer. Soap and detergent use can be cut back by up to 25%. The water will feel as if it is "softer" as the treatment causes a decrease in water surface tension. Generally, soap will lather up more. Skin will feel smoother and hair will be much more manageable because the scale particles no longer make it so frizzy.

6.3 Gardening and Irrigation

Garden irrigation with sprinklers becomes more reliable as the nozzles stay free of scale longer. Vulcan-treated water can be absorbed and processed better by plants. As there are less scale spots on the leaves your plants take up water and rain water better and look healthier.

6.4 A healthier Lifestyle

Mineral rich drinking water

Vulcan does not interfere with the natural composition of the drinking water. Important minerals remain in the water for a healthy diet. Especially young children and elderly people benefit from the healthy calcium and magnesium content that naturally is found in tap water.

Water tastes and smells better and gives food and beverages its natural flavor

Vulcan keeps the natural taste of water as it does not change its chemical composition. This gives you the best tasting water possible. Vulcan cleans the piping system once again and therefore cleans it from rust particles. Rust is gone and can no longer add its unwanted flavor any more.

6.5 Swimming Pools and Jacuzzis

Protect your private swimming pool and jacuzzi

Private swimming pools demand constant maintenance and careful monitoring. The circulation pumps process large amounts of water and are sensitive to scaling.

Vulcan makes pool cleaning much easier: scale on the water line is looser and easier to wipe off. Pool covers and tiles on the floor or walls will show less hard scale stains. Vulcan reduces deposits in the pipes and valves. The sensitive circulation pumps last longer, sand filter need less changing and you can cut down on chlorine tablets.

Jacuzzis: The combination of water, circulating air and pressure in a hot tub tremendously enhances scale build-up. Vulcan makes the cleaning of the tub easier and reduces deposits in the pipes and valves. Covers and tiles on the floor or walls will show less hard scale stains.

6.6 Heating and Solar Water Heating

Heating

When water is heated with oil, gas, electric or solar heating technologies, scale likes to settle on the heating elements and heat exchangers. The loss of energy due to the less efficient heat transfer is tremendous. Vulcan helps to reduce the scaling and extends cleaning intervals.

Water tanks in the primary and secondary circuit will need less cleaning and the frequency of cleaning periods will be extended.

When water is heated in a water heater or with a tankless water heater, hard water always leads to deposits on the heating elements. This layer inevitably causes a great reduction in the capability of the heat to transfer. A scale deposit of only 2mm (~0.078 inches) can lead to an energy loss of more than 15%. The increase in heating time leads to a tremendous rise in your power consumption.

Water heaters

Vulcan controls scale build-up in tankless water heaters permanently and reduces constant maintenance as heat exchangers get fewer deposits. Your water heater will work much more efficiently once again, and you can extend the time to your next service maintenance.

Heating systems regain full performance.

When water is heated in a hot water tank the hard water always leads to thick deposits on the heating elements. This layer inevitably causes a great reduction in the capability of the heat to transfer. With Vulcan, deposits are minimized and your heating performs at a much higher capacity again. Service maintenance intervals are extended. Typically, water heating bills will be substantially reduced.

Solar water heating

Using a solar powered water heater for your house is a smart green alternative to traditional heating methods. Vulcan prevents scale-build up in the system. It keeps the heat exchangers and distributor pipes clean. Furthermore, Vulcan reduces scale buildup in collectors, it protects hot water tanks and vacuum tubes and keeps the system from over-heating. There is no more need to circulate acids.

Protection for your solar water heating

The energy savings you took into consideration when purchasing a solar water heater may be drastically reduced due to scale deposits. Here, a scale layer of only 1 mm (~0.04 inches) may result in a decrease of efficiency of up to 40%. With Vulcan you save on energy, cleaning and repairs. This loss has to be compensated with regular fossil fuels or electric power and much of the savings you were planning to achieve will be obsolete.

6.7 Vulcan and Reverse Osmosis Filters (RO)

When Vulcan is installed before a RO-system it helps in two ways:

1. As calcium-crystals are smoother after the Vulcan treatment, this reduces deposits on the sensitive RO-filter membranes. The RO-system runs longer and more effectively.
2. The permeate (leftover water) is difficult to handle as it has a particularly high degree of water hardness after filtration. Here, Vulcan helps that the permeate can be better handled and prevents it from causing damage further down the drain.



RO system

6.8 Vulcan and Water Softeners

a) Vulcan replaces water softeners

Vulcan is the eco-friendly alternative to regular salt-based water softeners. It is not recommended for young children or older people to drink water that has been treated with a salt-based softener. In addition, the use of softeners is polluting the environment. When installing Vulcan, an old system can easily be circumvented by simply bypassing it.

b) Vulcan as an addition to water softeners

Vulcan is the eco-friendly alternative to regular salt-based water softeners. However, if you want to keep the softener running due to special reasons, you can save large sums of money when using Vulcan as an aid. The use of Vulcan will decrease the amount of salt that you need to add. This cuts down costs for salt, maintenance intervals will be extended, fewer malfunctions with backwash valves etc.



Vulcan installation with water softener

Throw out those expensive water softeners

Running a water softener is a costly measure. Large amounts of salt are needed to operate the system. On average, a homeowner faces expenses of 70-140 € (~\$ US 100-200) per year in salt alone. Needless to say, nobody likes carrying around bags of salt.

Furthermore, 30-80 gallons (115-300 l) of water are wasted each time the softener granule has to be washed. Malfunctions and repairs are likely with a built-in system. These can easily add up to hundreds of dollars in repair costs. Possible annual savings: 250 € (~\$ US 330).

Comparison

The purchase and installation of a water softener alone would cost at least 700 € (~\$ US 1000) to buy and another 35-85 € (~\$ US 50-120) for the installation by a plumber. Add annual operating costs and maintenance on top. For installation of water softener or bypassing procedures.

6.9 Vulcan and Well / Bore-wells

Wells are taking the water from deep down in the ground which often causes high contents of calcium, magnesium and other minerals in the water. Therefore, very often the well water quality is very hard to extremely hard. The Vulcan treatment offers a great solution for this. Typically, Vulcan is installed just before the suction pump - if possible with a distance of approx. 5 ft (1,5m) to the pump's motor. For submersible pumps it is recommended to install Vulcan at the exit of the hydrophor tank. Water quality: Well water quality also might contain other substances such as iron and manganese (see more in section 4.4)



6.10 Saving Money with Vulcan

Money savings in your private home

The use of the eco-friendly Vulcan water treatment saves you time and money from day one of its installation. It is a solid purchase for your home with a quick return on your investment.

Vulcan saves money around your home

- It protects the whole piping system in your home
- It reduces already existing deposits
- It helps to protect appliances such as washing machines, dishwashers, water heaters, heating systems etc.
- You save on maintenance costs and repairs
- Filters, shower heads, fixtures and tiles stay clean
- Vulcan saves on detergents, additives and fabric softeners

Efficiency calculation for your private home

Example of savings potential in an average home with 4 people*

	Annual savings potential	~ in €	~ in \$ US
1	Savings in energy (e.g. 1mm of limescale deposit= 15% more energy consumption) e.g.: 1 500 Euro of energy costs p.a.	325.00	430.00
2	De-scaling of water heater every two years by a specialist at 150 Euro/ average	75.00	95.00
3	Savings of up to 50% on laundry detergent (e.g. 9 Euro/month) at a saving rate of 30%	30.00	40.00
4	Savings on softeners for your washing machine	10.00	13.00
5	Minimal use of salt for your dishwasher	10.00	13.00
6	Savings on aggressive cleaning agents	15.00	20.00
7	Savings on shampoo, soap or expensive skin care products	20.00	26.00
8	Less time spent cleaning your house, 10 min/week (e.g. cleaning costs at 8 Euro/h)	70.00	93.00
9	Longer life span of all appliances and pipes (washing machine, coffee machine, iron, water heater, etc.)	250.00	335.00
	Typical annual savings	735.00	980.00

*The actual savings may vary due to the exact degree of water hardness.



Savings in installation costs

Vulcan saves you installation costs. Most water treatments need to be built in the piping system and therefore require a professional plumber to do the installation. Vulcan is installed without any tools, within only a few minutes by yourself. You save money as you do not need to hire anyone.

Return on Investment (ROI): Amortization of purchase

Depending on the savings rate and the size of unit that gets purchased the amortization of Vulcan will be achieved after approx. 1.5 years on average. Vulcan will protect your house for the next 20 years and longer.

Increase the value of your home

Installing an eco-friendly maintenance-free water treatment that conditions all the water running in your home will increase the value of the house for you, your children or for the potential buyer in case you want to put it on the market.

7. Commercial and Industrial Applications

7.1 Condominiums and Large Buildings

Water treatment: Condominiums and large buildings

Vulcan is your electronic anti-scale system that treats hard water without the use of salt or chemicals



Managing a large building demands constant observation of all technical equipment, sanitary stations, outdoor areas, etc. Vulcan helps to improve manageability, sustainability and profitability in many areas. Vulcan helps water-fed appliances to reach their maximum life expectancy and keeps their maintenance to a minimum.

The **Vulcan-Impulse-Technology** treats the water with special electronic impulses that take away the adhesive power of the scale particles. Scale components are simply washed away with the water as a fine powder. Vulcan also carefully dissolves already existing deposits. The build-up process is reversed and the piping system is clean once again. In addition, pipes consisting of metal often suffer from corrosion. The electronic Vulcan impulses generate a metal-carbonate protective layer that prevents pitting corrosion.

Benefits of using Vulcan

- ▶ Reduction of scale deposits in the piping system
- ▶ Less time and effort on maintenance in building and facilities
- ▶ Machinery and equipment performs more reliably: kitchens, cooling towers, heating system etc.
- ▶ Faster cleaning of kitchens and bathrooms
- ▶ Filters, shower heads and basins stay cleaner
- ▶ Considerable savings on cleaning agents
- ▶ Cleaner sprinkler nozzles for garden irrigation
- ▶ Food and beverages keep their natural taste



Vulcan carefully dissolves already existing deposits in the piping system. The scale build-up process is reversed and the pipes gradually become clean again. This take-out process will not block up your pipes or drain because the treated crystals are microscopic in size and wash away in the water.

- ▶ Vulcan stops scaling in pipes and appliances
- ▶ Vulcan gently sanitizes the piping system
- ▶ Vulcan protects against rust damage and perforation

Installation

Vulcan is a **Do-It-Yourself** product and easily to installed within a few minutes without the need to cut pipes. You do not need any tools.



Vulcan has to be placed at the main water supply – this is usually close to the water meter. Vulcan is suitable for indoor and outdoor installation.



7.2 Educational Institutions

Water treatment: Educational institutions

Vulcan is your electronic anti-scale system that treats hard water without the use of salt or chemicals



Managing an educational facility demands constant observation of all technical equipment, sanitary stations, outdoor areas, etc. Vulcan helps to improve manageability, sustainability and profitability in many areas. Vulcan helps water-fed appliances to reach their maximum life expectancy and keeps their maintenance to a minimum.

Vulcan carefully dissolves already existing deposits in the piping system. The scale build-up process is reversed and the pipes gradually become clean again. This take-out process will not block up your pipes or drain because the treated crystals are microscopic in size and wash away in the water.



- ▶ Vulcan stops scaling in pipes and appliances
- ▶ Vulcan gently sanitizes the piping system
- ▶ Vulcan protects against rust damage and perforation

Benefits of using Vulcan

- ▶ Reduction of scale deposits in the piping system
- ▶ Less time and effort on maintenance in building and facilities
- ▶ Machinery and equipment performs more reliably: kitchens, cooling towers, heating system etc.
- ▶ Faster cleaning of kitchens and bathrooms
- ▶ Filters, shower heads and basins stay cleaner
- ▶ Considerable savings on cleaning agents
- ▶ Cleaner sprinkler nozzles for garden irrigation
- ▶ Food and beverages keep their natural taste



Applications

- ▶ Building maintenance
- ▶ Dormitories
- ▶ Kitchens and restaurants
- ▶ Sport facilities
- ▶ Swimming pools
- ▶ Science laboratories
- ▶ Gardening and greenhouse



Installation

Vulcan is a **Do-It-Yourself** product and easily to installed within a few minutes without the need to cut pipes. You do not need any tools.



Vulcan has to be placed at the main water supply – this is usually close to the water meter. Vulcan is suitable for indoor and outdoor installation.



7.3 Swimming Pools and Spas

Water treatment: Swimming pools and spas

Vulcan is your **eco-friendly** electronic anti-scale system that treats hard water without the use of salt or chemicals



Swimming pools are complex systems to operate and demand high cleaning effort and complicated water treatment procedures in order to comply to regulations. Their pumping and filtration systems are very sensitive to scaling. Cleaning consumes a tremendous amount of time and money on a daily basis.

- ▶ Reduction of scale deposits in the whole piping system
- ▶ Longer life and improved performance of filters and pumps
- ▶ Extensive reduction of cleaning effort
- ▶ Savings in cleaning agents
- ▶ Heat exchangers operate more efficiently
- ▶ Reduction of chemicals that control bacteria and the pH-levels
- ▶ Reduction of biofilm

Vulcan significantly reduces scaling in and around the swimming pool, in the whole piping system and in the filters and pumps.

Swimming pools are half-open loop systems which suffer constant water loss as the pool water evaporates. Even low water hardness levels lead to harmful scale deposits that constantly need to be cleaned. Vulcan reduces the cleaning effort for the pool itself, the water line, for tiles, grids, floors and walls. Showers, showerheads, faucets and toilets are also much easier to be maintained.

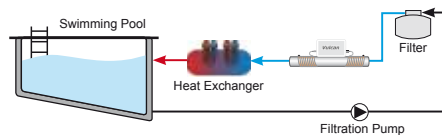

Installation recommendations: As ideal setting, Vulcan should best be installed *before* the heat exchanger. If possible, the placement should also be *after* the filters (sand filter, active carbon filter, etc).

Pool water demands constant maintenance and several chemicals need to be added to keep bacteria, algae, and air quality in compliance with standards. Vulcan significantly improves the water quality and with this the effectiveness of certain substances.

Pool cleaning agents are used to fight the scaling on the waterline, in grids, on tiles, or the pool's surrounding surfaces. Vulcan minimizes scaling which results in a much easier cleaning process together with a the reduction of cleaning agents and chemicals by up to 50%.

The **disinfection** of pool water is mostly secured by adding chlorine (Cl). Products range from granules to liquids, tabs or sticks. The addition of chlorine can often be reduced by up to 10-25 percent. An alternative product is active oxygen. Please cut back step by step by starting with a reduction of 10 percent.



pH adjustor products either reduce or raise the pH-level and control the total alkalinity in pool water. They are added in order to rebalance the pH which has been disturbed by the addition of chlorine or oxygen. In line with this, the use of adjustor products can be reduced in the same ratio to which the disinfectant product has been reduced. For example, if you reduce chlorine by 15% you can also reduce the pH-adjustor by 15%.

7.4 Hospitality: Hotels, Restaurants, Cafés

Water treatment: Hospitality: hotels, restaurants, cafés

Vulcan **eco-friendly** water treatment products are the salt-free alternative to traditional water softeners in hospitality applications



The hospitality industry goes through a large quantity of water on a daily basis. Restaurants need water for food preparation, such as drinking water and in the kitchen. Furthermore, laundry service, swimming pools, heating or cooling tower operations are just a few examples how hotels utilize water.

Benefits of Vulcan

- ▶ Reduces scale deposits in the piping system
- ▶ Longer life and improved performance of appliances
- ▶ Reduction in cleaning time and labour costs
- ▶ Reduction in heating costs
- ▶ Fewer maintenance visits required on water heaters, washing machines, etc.
- ▶ Savings on soap and cleaning agents
- ▶ Softer towels and bed linen

Application Examples

- ▶ Hotels and Resorts
- ▶ Restaurants and Kitchens
- ▶ Wellness Centers
- ▶ Swimming Pools
- ▶ Food Processing
- ▶ Cooling Towers
- ▶ Golf Courses
- ▶ Camping Grounds
- ▶ Sport Facilities



Restaurant kitchens often have problems with scale deposits, bacterial growth or unpleasant odors. Several studies explain the benefits of Vulcan in applications such as ice machines, grease traps and kitchen equipment. Pictures a/b show the results in a grease trap before and after treatment. As Vulcan works without chemicals or salt, the natural taste of water is preserved. Vulcan reduces the amount of scale deposits. It offers you a permanent solution without ongoing costs, repairs or replacements.

Vulcan References from Hotels and Restaurants **Display your environmental concern**



"... After a short period of time we noticed a high level of limescale developing on the ice makers. These calcifications could only be cleared bit by bit, which is a time consuming process. To avoid potential losses a short-term limescale filter was installed. The operating time of this filter is limited, however, and thus results in high costs.

We installed the Vulcan 5000 and the limescale which accumulates especially in the crushed ice makers can now be easily removed as it is converted into fine-grained powder. ..."

CWT provides you with complimentary stickers of choosed languages to place in your facilities, which make your clients aware of your concern about the environment.

In an effort to minimize our impact on the environment, the water in our hotel/restaurant is treated with eco-friendly water treatment.

Nello sforzo di proteggere l'ambiente, eseguiamo nel nostro albergo/ristorante il trattamento ecologico delle acque.

In Rücksicht auf die Umwelt, ist das Wasser in unserem Hotel/Restaurant mit umweltfreundlicher Wasseraufbereitung behandelt.

7.5 Medical: Hospitals, Nursing Homes, Residences

Water treatment: Medical: hospitals, nursing homes, residences Vulcan eco-friendly water treatment products are the salt-free alternative to traditional water softeners in medical applications



Hospitals, nursing homes and health care facilities all go through a large quantity of water on a daily basis. Traditional salt-based water softeners produce sodium-rich water and are not recommended for elderly patients suffering from hypertension, heart and circulatory problems – Vulcan is the solution of choice.

Benefits of Vulcan

- ▶ Longer life of appliances and equipment
- ▶ More sanitary environment for patients and staff
- ▶ Reduced cleaning and maintenance costs of equipment
- ▶ Patients suffering from eczema will notice an improvement in the texture of their skin
- ▶ Less detergents and soaps will be needed
- ▶ Reduction of chemical and salt costs
- ▶ Chlorine and ammonia will have a more moderate odor

Application Examples

- ▶ Hospitals and Clinics
- ▶ Nursing Homes
- ▶ Dental Clinics
- ▶ Rehabilitation Centers
- ▶ Spas and Wellness Centers
- ▶ Pharmaceutical Factories
- ▶ Post-operative Care Facilities



Vulcan does not alter the chemical composition as it does not add salt to the water. Important minerals such as calcium and magnesium remain in the water for your benefit. Vulcan reduces the amount of bacterial growth by starving them of nutrients contained in scale, thus, reducing biofilm.

Studies show that Vulcan creates a more sanitary environment while providing healthy water for patients and staff alike. Vulcan is a perfect salt-free, eco-friendly, labor and cost-saving solution to your hard water problems.

Vulcan Reference from a Health Care Service



"... a couple of months ago we had the Vulcan S250 installed inside the hospital. We can identify considerable benefits of the unit installed. We can barely see any scale deposits on the shower heads for example any more. This saves manpower and costs of the replacement of sanitary equipment.

We can honestly recommend the unit installed by Christiani Wassertechnik GmbH ..."



Without treatment



With Vulcan treatment



7.6 Agriculture: Plants, Livestock, Machinery

Water treatment: Agriculture: plants, livestock, machinery Vulcan eco-friendly water treatment products are the salt-free alternative to traditional water softeners in agricultural applications



Water is a valuable resource which needs to be managed properly to maximize efficient usage. When hard water is used to irrigate crops (corn, soy-beans, etc.) scale deposits form on plants and their leaves which obstruct contact with sunlight. This hinders the process of photosynthesis and therefore the growth of your plants.

Often scale acts as a magnifying glass with its crystal structures, which burns the plants. Salt-based ion exchangers have a negative effect on the environment in agricultural applications because of residual nitrates that leach into the ground water. Because of this salty discharge, traditional water softeners are not eco-friendly. With strict regulations and restrictions on enterprises using "Eco-Friendly" or "Organically Grown" labels, Vulcan's chemical-free method is the solution of choice.

Application Examples

- ▶ Irrigation Fields and Sprinklers
- ▶ Water Feeders for Animals
- ▶ Organic Food Plants
- ▶ Poultry Farms
- ▶ Livestock Farming
- ▶ Green Houses
- ▶ Vineyards
- ▶ Fruit Plantations



The Vulcan effect lowers the surface tension of the water making it easier for plants to absorb. Vulcan is not only effective in the case of irrigation, but also in providing fresh water to livestock and poultry. In these applications, the clearing of nozzles and general maintenance of your water-related equipment will be required at much longer intervals. Bacteria will neither have a host environment to thrive in nor will not be able to accumulate and negatively affect plants and livestock.

Vulcan Reference from a Tree Nursery in Greece



Without treatment



With Vulcan treatment

"... I also have to emphasize on the fact that all these years the leaves of the plants had a white color and not the well known green color. That is, of course because of too much scale in the water.

Installing the Vulcan S25 device, I found out that there is no more white sedimentation on the leaves and soil. Most of all I realized a big improvement in the growth of my plants. I also found out that there is better and quicker lathering, when we wash our hands or even clothes etc.

Finally, I must say that I really found the solution to my problem, which has been bothering me for all these years..."

7.7 Industrial Applications

Water treatment: Industrial applications

Vulcan **eco-friendly** water treatment products are the salt-free alternative to traditional water softeners in industrial applications



The Vulcan-Impulse-Technology treats the water with special electronic impulses that take away the adhesive power of the scale. Scale is simply washed away with the water as a fine powder. Vulcan provides solutions for all types of scale-related problems in many industrial applications.

Benefits of Vulcan

- ▶ Maximized life of production equipment
- ▶ Lengthens maintenance intervals
- ▶ Increase in overall productivity
- ▶ More efficient use of energy consumption
- ▶ Reduction of chemical and salt costs
- ▶ An easier and less-frequent cleaning process
- ▶ No production loss during installation
- ▶ A fast pay-back of acquisition costs

Application Examples

- ▶ Cooling Towers
- ▶ Heat Exchangers
- ▶ Chillers
- ▶ Refrigeration Systems
- ▶ Vacuum Pumps and Valves
- ▶ Grinders and Mixers
- ▶ Condensers
- ▶ Industrial Ovens and Presses
- ▶ Food Processing



Cooling towers often suffer from scale build-up caused by the vaporization and cycling of water. Scale cannot evaporate, so when a new cycle of water is introduced, the scale builds up more and more. This type of hard compounded scale is expensive to remove so frequently.

Vulcan reduces the amount of scale deposits and reduces the amount of required maintenance. It offers you a permanent solution without on-going costs, repairs or replacements.

Client List

- ▶ Alcatel
- ▶ Bayer-Leverkusen
- ▶ BOSCH
- ▶ DaimlerChrysler
- ▶ Dynamit Nobel
- ▶ Hyatt Hotels
- ▶ Mc Donald's
- ▶ Mövenpick
- ▶ SHELL
- ▶ Siemens
- ▶ Universität München
- ▶ Viessmann
- ▶ Volkswagen

Case Study from a Cooling Tower in Japan

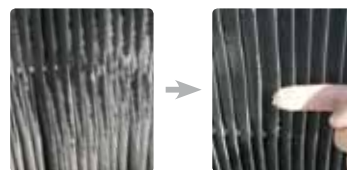

... Verification of the effectiveness:

After installation of the Vulcans, the status of the cooling towers was inspected without using any water treatment chemicals. Even after approximately six months, almost no scale buildup was observed inside the refrigerators and the heat exchanger tubes, and no water pollution warning was displayed. (Usually, without water treatment chemicals, the water quality deteriorates and a water pollution warning is displayed.) Silica which was adhered on the cooling towers was easily removed with the wipe of a finger. With these results, the effectiveness of the Vulcan installation could be confirmed. ..."

7.8 Maritime Applications

Water treatment: Maritime applications

Vulcan water treatment is the **eco-friendly** and **salt-free** solution to prevent scale and corrosion in maritime applications



A ship carries a lot of machinery and equipment, which come in contact with water. Scale deposits in the piping system can cause fatal damage to engines and turbines, which are very expensive to repair.

In the daily use of water on board (in bathrooms, kitchens, swimming pools, etc.) Vulcan helps to eliminate problems caused by scale.

Benefits of using Vulcan

- ▶ Reduction of scale deposits in the whole piping system
- ▶ Minimizes overall operating costs and maintenance visits
- ▶ Maximizes life of appliances and equipment
- ▶ Reduces bacterial growth and biofilm (typical breeding ground for legionella bacteria)
- ▶ No need of salt or aggressive chemicals
- ▶ pH levels remain unchanged - preventing corrosion
- ▶ Vulcan is also effective in low-flow areas
- ▶ Reduces hot water energy consumption

Application Examples

- ▶ Cruise Ships
- ▶ Passenger Ships
- ▶ Cargo Ships
- ▶ Naval Ships
- ▶ Research Ships
- ▶ Fishing Ships
- ▶ Merchant Ships
- ▶ Yachts
- ▶ Ferries ...



Engines: Vulcan controls limescale deposits in the water cooled jackets, in transfer lines or coolers. Vulcan treats scale build-up in the heat exchangers (hot water production) or in the heat chambers in engines.

Ballast tanks: Ballast water will be handled easier and scale deposits will be reduced.

Potable water: Vulcan controls scale deposits in the desalination and works with distillation or reverse osmosis equipment.

Wastewater: Vulcan smooths the incrustations of all wastewater transport ways.

Vulcan helps:

- Piping systems
- Pumps and valves
- Condensers
- Heat exchangers
- Air conditioners
- Cooling towers and chillers
- Tanker equipment
- Engines
- Steam turbines
- Potable water
- Wastewater
- Ballast tanks
- Restaurants and kitchens
- Ship sporting facilities
- Swimming pools and spas
- Ship hospitals

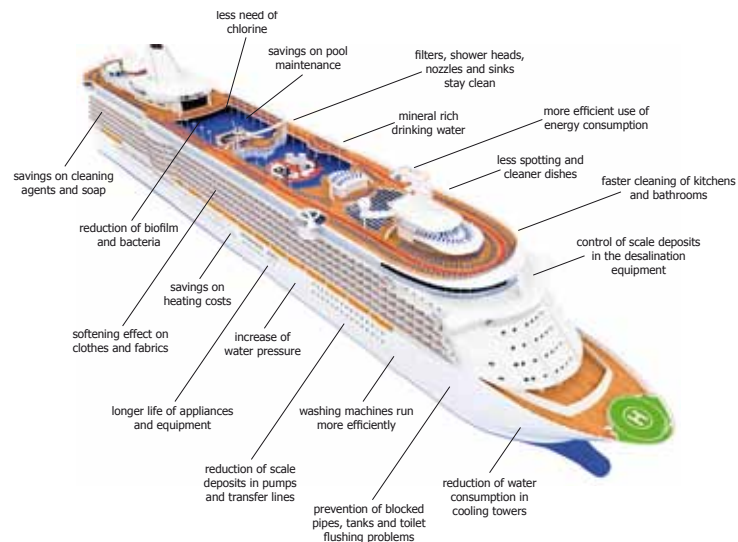

7.9 Farming Applications

Water treatment: Farming applications

Vulcan water treatment is the **eco-friendly** and **salt-free** solution against scale and corrosion



Scale is a big problem in farming. When hard water is used, scale deposits will decrease the efficiency of your whole farm. This will cost you a lot of time, money and energy. Scale deposits are a perfect breeding ground for bacterial growth and algae. Illnesses, infections and a decrease in healthy animal growth are the results.

Advantages of using Vulcan

- ▶ Reduction of scale deposits in the whole piping system
- ▶ Minimizes operating costs and maintenance visits
- ▶ Maximizes life of appliances and equipment
- ▶ Less time and effort spent on cleaning
- ▶ No need of salt or aggressive chemicals
- ▶ pH levels remain unchanged - preventing corrosion
- ▶ The water tastes better - the animals are drinking more water and are healthier
- ▶ Less biofilm

Benefits for your Farm

- ▶ Incubators stay clean and the humidification system operates effectively
- ▶ Improved effectiveness of cooled refrigeration equipment
- ▶ Cleaner drinking cones and cooling panels
- ▶ Nipple drinkers, bell drinkers and spray nozzles are clear of blockages
- ▶ Increased performance of water heaters
- ▶ Decrease of bacteria and algae levels
- ▶ Decrease of infections and illnesses



Healthy water for healthier animals

Vulcan provides fresh and healthy water for your animals. The animals' health is improved as bacterial and algae growth is reduced by Vulcan. The reduction of algae levels in the water leads to a substantial improvement in the water's taste. This motivates more drinking which typically raises animal health. You will see better growth rates and less illness (e.g. reduction in poultry leg infection).

Vulcan improves animal health

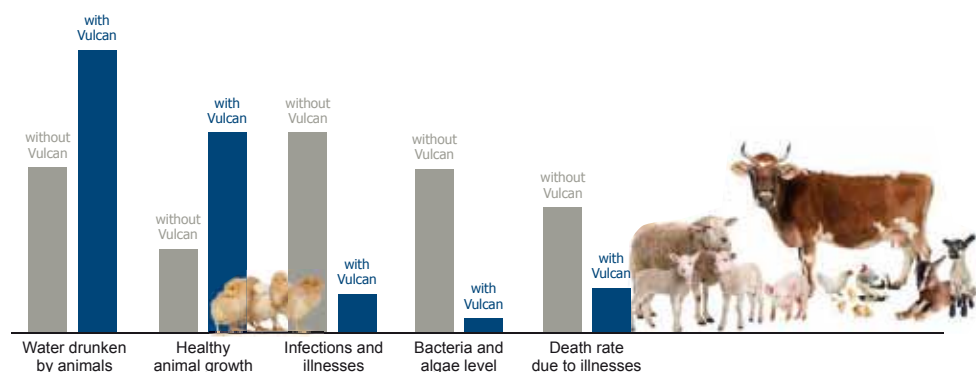

7.10 Poultry Applications

Water treatment: Poultry applications

Vulcan water treatment is the **eco-friendly** and **salt-free** solution against scale and corrosion



Scale is a big problem in farming. When hard water is used, scale deposits will decrease the efficiency of your whole poultry farm. This will cost you a lot of time, money and energy. Scale deposits are the perfect breeding ground for bacteria and algae. Illnesses, infections and a decrease in healthy bird growth are the results.

Advantages of using Vulcan

- ▶ Reduction of scale deposits in the whole piping system
- ▶ Minimizes operating costs and maintenance visits
- ▶ Maximizes life of appliances and equipment
- ▶ Less time and effort spent on cleaning
- ▶ No need of salt or aggressive chemicals
- ▶ pH levels remain unchanged - preventing corrosion
- ▶ The water tastes better - the animals are drinking more water and are healthier
- ▶ Less biofilm

Benefits for your Poultry Farm

- ▶ Incubators stay clean and the humidification system operates better
- ▶ Improved effectiveness of cooled refrigeration equipment
- ▶ Cleaner drinking cones and cooling panels
- ▶ Nipple drinkers, bell drinkers and spray nozzles are clear of blockages
- ▶ Increased performance of water heaters
- ▶ Decrease of bacteria and algae levels
- ▶ Decrease of poultry leg infection



Healthy water for healthier animals

Vulcan provides fresh and healthy water for your animals. The animals' health is improved as bacterial and algae growth is reduced by Vulcan. The reduction of algae levels in the water leads to a substantial improvement in the water's taste. This motivates more drinking which typically raises animal health. You will see better growth rates and less illness (e.g. reduction in poultry leg infection).

Vulcan improves animal health

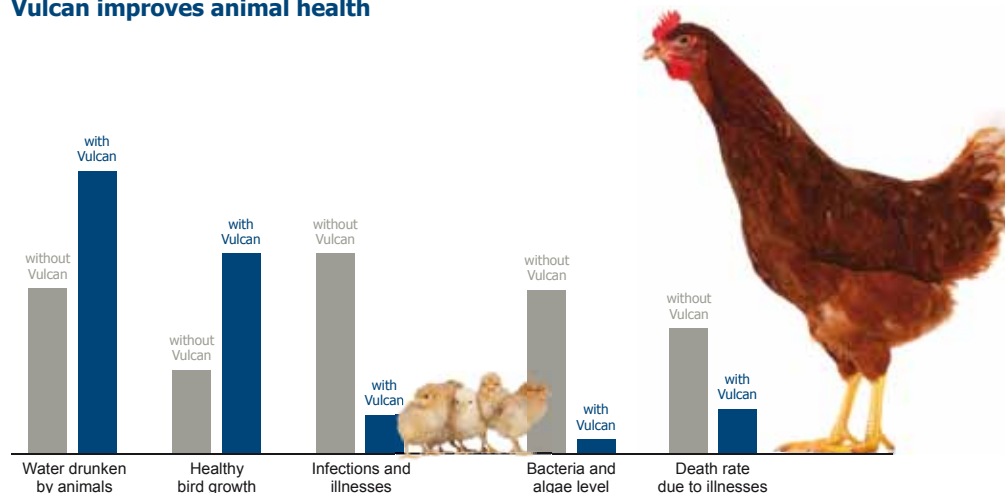

8. Commercial and Industrial Applications: Benefits



8.1 Facility Management

Managing a building, hotel or business demands constant observation of all technical equipment, sanitary stations, outdoor areas, etc. Vulcan helps to improve manageability, sustainability and profitability in many areas.

Vulcan helps water-fed appliances to reach their maximum life expectancy and keeps their maintenance to a minimum.

8.2 The Piping System

a) Reduction of scale deposits in the piping system

Vulcan takes away the adhesive power of scale particles so that scale is simply washed away with your water as a fine powder.

b) New scale-formation is stopped

Vulcan dismantles already existing deposits. Vulcan carefully dissolves already existing deposits in the piping system. The scale build-up process is reversed and the pipes gradually become clean again. This take-out process will not block up your pipes or drain because the treated crystals are microscopic in size and wash away in the water.

c) Corrosion protection

Metal pipes often suffer from pitting corrosion. The electric Vulcan impulses generate a metal-carbonate protective layer that prevents pitting corrosion.

d) Increased water pressure

Vulcan sanitizes the pipes from scale deposits and can even restore a pipe's full diameter. Water can flow freely again and you regain normal water pressure.

e) Vulcan minimizes rust

In most cases whenever there are scale deposits you will find rust shortly thereafter. The rust typically imbeds itself in the scale deposits. Because rust oxides are red, the scale deposits in metal pipes then often appear red in color, too. When the Vulcan treatment reduces scale, it also takes away rust with it.

f) Vulcan minimizes bacterial growth in pipes

Thick scale deposits with their uneven surfaces are the perfect breeding ground for bacteria. Once the scale is gone, there are no more nesting areas where bacteria can grow.

8.3 Technical Appliances

Water heaters

Vulcan controls scale build-up in tankless water heaters permanently and reduces maintenance as heat exchangers get fewer deposits. Your water heater will work much more efficiently once again, and you can extend the time to your next service maintenance. Typically, the water heating bills will be substantially reduced.

Heating systems regain full performance

When water is heated in a hot water tank or with a tankless water heater the hard water always leads to thick deposits on the heating elements. This layer inevitably causes a great reduction in the capability of the heat to transfer. With Vulcan, deposits are minimized and your heating performs at a much higher capacity again.

Solar water heating

Vulcan prevents scale build-up in the system. It keeps heat exchangers and distributor pipes clean. Furthermore, Vulcan reduces scale build-up in collectors, it protects hot water tanks and vacuum tubes, and keeps the system from over-heating. There is no more need to circulate acids.

Cooling towers

Vulcan significantly reduces scale deposits. Bleed water is no longer toxic and bacterial contamination is minimized. With Vulcan, the cooling tower can be operated at higher cycles of scale concentration which minimizes water usage.

8.4 Vulcan in Hotels & Restaurants

Cleaner bathrooms

Shinier, smoother surfaces in the bathroom again on baths, sinks, fixtures, shower heads, etc. You will quickly notice that scale is still visible but acts like a fine "dust" which can be removed easily with a damp cloth. Notably less cleaning agents are needed and the use of

harsh detergents can now be avoided. This saves many hours when cleaning the rooms.

Kitchen and kitchen appliances

Kitchen surfaces, sinks, faucets and fixtures stay cleaner. You will quickly notice that scale is visible but acts like a fine 'dust' which can be removed easily with a damp cloth. Surfaces and tiles will be smoother and shinier again.

Cleaner dishwashers

Dishwashers operate with less detergent and less additives. The use of dishwasher detergent can be reduced by up to 25%. Typical spotting on dishware is reduced or no longer apparent.

Laundry and washing machines

Cleaning is more effective as Vulcan-treated water lathers noticeably more. The same amount of detergent will give you better cleaning results. You can often reduce the amount of washing detergents in your daily use or stay away from very aggressive agents. Furthermore, Vulcan extends the life of the machine's heating element.

Grease traps

Vulcan improves the handling of grease separators in two ways: The grease that is collected on top forms less clusters and is more homogenous which makes it easier to pump it into an external tank. The Vulcan-treatment also prevents the remaining water from scaling in the tank; pipes, valves and pumps stay cleaner.

Gardening and irrigation

Garden irrigation with sprinklers becomes more reliable as the nozzles stay free of scale longer. Vulcan-treated water can be absorbed and processed better by plants. As there are less scale spots on the leaves your plants take up water and rain water better and look healthier.

Reverse osmosis filters

Reverse osmosis filters for your tap drinking water last longer. Water filters and RO-membranes will work more efficiently and the permeate is easier to handle.

Spas, swimming pools and jacuzzis

Swimming pools: Vulcan makes pool cleaning much easier: scale on the water line is looser and easier to wipe off. Pool covers and tiles on the floor or walls will show less hard scale stains. Vulcan reduces deposits in the pipes and valves. The sensitive circulation pumps last longer, sand filter need less changing and you can cut down on chlorine tablets.

Jacuzzis: The combination of water, circulating air and pressure in a hot tub tremendously enhances scale build-up. Vulcan makes the cleaning of the tub easier. Vulcan reduces deposits in the pipes and valves. Covers and tiles on the floor or walls will show less hard scale stains.

Spa Treatment Areas & Wellness: Shower heads stay clean longer. Soap and detergent use can be cut back by up to 25%. The water will feel as if it is "softer" (due to a decrease in water surface tension). Generally, soap will lather up more. Skin will feel smoother and hair will be much more manageable because the scale particles no longer makes it so frizzy.

8.5 A healthier Lifestyle

Mineral rich drinking water

Vulcan does not interfere with the natural composition of drinking water. Important minerals remain in the water for a healthy diet. Especially young children and elderly people benefit from the healthy calcium and magnesium content that naturally is found in tap water.

Water tastes and smells better and gives food and beverages its natural flavor

Vulcan keeps the natural taste of water as it does not change its chemical composition. This gives you the best tasting water possible. Vulcan cleans the piping system once again and therefore cleans it from rust particles. Rust is gone and can no longer add any unwanted flavor any more.



9. The Commercial and Industrial Applications: Savings Potential

Financial Payback in Commercial and Industrial Applications

The use of the eco-friendly Vulcan water treatment saves you time and money from day one of the installation. It is a solid purchase for your operation with a quick return on investment.

9.1 Monthly Savings in Large Buildings

- Pipes and appliances stay cleaner
- More efficiency of heating systems
- Minimized cleaning costs
- Less repairs of equipment
- No more maintenance or salt purchases for water softeners
- The monthly savings can amount up to 15-20% on your current costs



9.2 Increase the Efficiency of the Heating System

When water is heated in a water heater or with a tank-less water heater, hard water always leads to deposits on the heating elements. This layer inevitably causes a great reduction in the capability of the heat to transfer. A scale deposit of only 2mm (~0.078 inches) can lead to an energy loss of more than 15%. The increase in heating time leads to a tremendous rise in your power consumption.

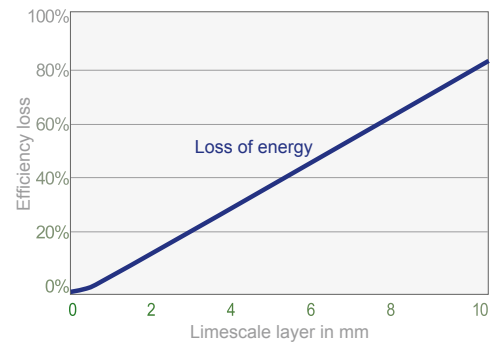

9.3 Your Hotel Operation – Some Cost Saving Factors

The analysis of the cost saving potential for your hotel includes factors such as:

- Number of rooms
- Number of bathrooms/toilets
- Number of restaurant kitchens - and size of them
- Size of pool and spa area
- Daily laundry volume
- Type and dimensions of the heating system
- Number of cooling towers and dimensions
- Garden area that needs irrigation
- Daily use of water
- etc.



These factors quickly multiply and add up to a considerable cost saving potential. Please contact your local distributor for a detailed cost analysis.

9.4 Throw out that expensive Water Softeners

Running a water softener is a costly measure. Large amounts of salt are needed to operate the system. Hundreds of gallons of water are wasted each time the softener granule has to be washed. Malfunctions and repairs are likely with an built-in system. These can easily add up to hundreds of dollars in repair costs.

9.5 Savings in Machinery Operations

Running costs for Machinery

Vulcan improves the performance and efficiency of many machines that operate with water. The use of Vulcan saves you time and money from day one of the installation.



10. Vulcan and its Effect on Machinery and Equipment

10.1 Heating and Heat Exchangers

When water is heated, scale settles on the heating elements and heat exchangers. This happens in oil, gas, electric or solar heating technologies alike. The loss of energy due to the less efficient or blocked heat transfer is tremendous and the heat transmission coefficient decreases. Vulcan helps to reduce the scaling, and water tanks in the primary and secondary circuits will need less cleaning. The frequency of cleaning periods can be extended. Vulcan is effective on all types of exchangers: tube bundle heat exchangers, spiral tube heat exchangers, plate heat exchangers, ripped recuperators, etc.

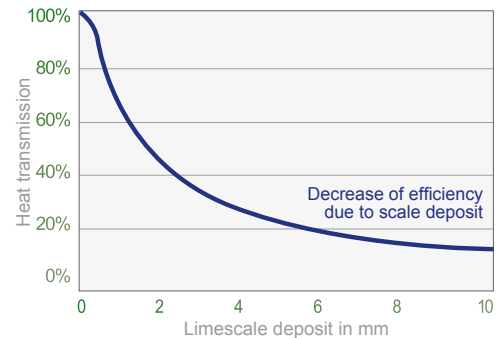

Background knowledge on water heating systems

Water heater in private houses and buildings

Regulations for water temperature in houses or buildings state that the warm water pipes shall not carry water hotter than 64°C (147°F). Any temperature above this point would create a risk of serious skin burn. Furthermore, the water should be heated to meet a minimum of 60°C (140°F) to control legionella.

Therefore: water is normally heated to 60°-64°C (140°-147°F).

a) Standard water heaters: electric, gas, oil (with a tank)

Standard water heaters operate with a heating element temperature anywhere from 65°C (149°F) in order to reach the water temperature of min. 60° (147°F) and max. 64°C (147°F). The water is slowly and economically heated in a tank where the water is stored for usage. Often heating element peak temperatures range around 85°C (185°F).

b) On-demand (instant) water heaters: electric, gas, oil

On-demand water heaters do not have a tank. They quickly heat the water from cold water to warm/hot the moment warm water is needed. The cold water needs to be heated within a few seconds which demands higher heating element temperatures. These instant water heaters may operate with higher heating element temperatures than 95°C (203°F).

c) Under 95°C (203°F) – the Vulcan effect in your water heater

The general rule for water heater systems is: if the *heating element surface temperature* is less than 95°C (203°F), you will see very good results with the Vulcan water treatment.



On-demand heater

d) Above 95°C (203°F) – the Vulcan effect in your water heater

What does it mean for the success of the Vulcan water treatment if the heating element temperature is higher than 95°C (203°F)?

At home: The Vulcan water treatment is highly recommended even if you operate a water heater with an heating element temperature above 95°C (203°F) because Vulcan will be effective in all areas around your house.

What will you see? In a water heater you will notice that the scale that typically lines the inside walls of your heater will be significantly reduced. Even if some scale forms on the walls after some weeks, the scale can be easily removed by wiping it. The heating element will also show less scale deposits as Vulcan reduces this scaling to a certain degree but maybe not as significantly as in all the other areas. The Vulcan water treatment protects all areas. However, a heating element that operates above 95°C (203°F) is the one part that will show some scaling.

In a factory setting: If you are operating a large sized water heating system (e.g. with a large water tank) which has to be cleaned frequently by professional services, the scaling on walls will be reduced significantly. This way maintenance intervals are reduced. Furthermore, the few scale deposits that may have formed can be more easily removed. The typical experience shows that use of chemicals can be limited to a minimum and may even be discontinued. The Vulcan water treatment protects all areas. The heating element will show less scale but not as significantly as in other areas. Results are very good up to 95°C (203°F) but will diminish somewhat if temperatures rise above that (e.g. 130°C (266°F)).



10.2 Grease Traps

Many businesses in the food processing industry, in kitchens, restaurants, carwashes, and many other companies need to operate grease separator. Vulcan improves the handling of grease traps in two ways: The grease that is collected on top forms fewer clusters and is more homogenous which makes it easier to pump it into an external tank. Vulcan also prevents the remaining water from scaling in the tank and pipes, and valves and pumps stay cleaner.

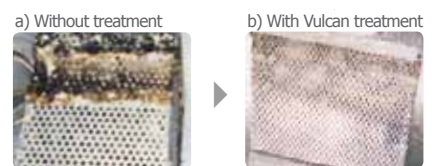

10.3 Ice Machines

Processing water form into ice consumes high amounts of energy. The ice cube's quality largely depends on the water quality which is improved by Vulcan just before the actual ice-making process.

The benefit: Ice machines build less deposits during production which keeps machines running more reliably.



10.4 Solar Water Heating

Water treatment: Solar water heating

Vulcan eco-friendly water treatment products prevent scale and corrosion in solar water heating systems



Using solar powered water heaters are a smart green alternative to traditional heating methods. They utilize sustainable resources, help the environment and save money. In order to ensure the effective performance of these eco-friendly heating systems, engineers recommend the use of an anti-scale product.

Hard water naturally forms scale when there is an increase in temperature or change of pressure. This leaves deposits on the tubes, the heat exchangers, the collectors or tanks. The scale prevents heat from transferring efficiently, therefore the working capacity of your machinery is minimized, increasing your back-up energy bill.

Vulcan reduces scaling and effectively dissolves existing deposits in solar water heating systems.

Application Examples

- ▶ Private Homes
- ▶ Green Buildings
- ▶ Factories and Farms
- ▶ Apartment Buildings
- ▶ Hotels and Resorts
- ▶ Universities
- ▶ Swimming Pools
- ▶ Sports Complexes



Vulcan helps to benefit your system with:

- ▶ Cleaner heat exchangers and distributor pipes
- ▶ Reduces scale build-up in collectors
- ▶ Protects hot water tanks and vacuum tubes
- ▶ Protects a system from over-heating
- ▶ No need to circulate acids
- ▶ pH levels remain unchanged, preventing corrosion
- ▶ Reduces malfunctioning of valves in primary circuits
- ▶ Fewer maintenance visits required for your equipment

Vulcan is the optimal solution for solar heating systems.

Installation Examples

1. Solar Water Heating System

For best results, Vulcan should be placed on the cold water inlet to the heat exchanger.

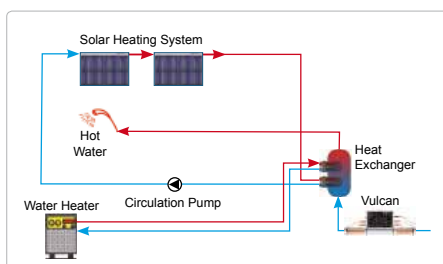

2. Solar Pool Heating and Filtration System

For optimal results, Vulcan should be placed between the filter and the heat exchanger.

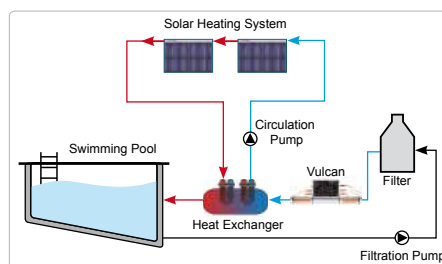

10.5 Snow Production

Water treatment: Snow production

The Vulcan **eco-friendly** water treatment system improves the water quality and maximizes your snow production – for better snow that lasts longer



The quality and quantity of snow in snow production is largely affected by the water quality. The Vulcan Electronic - Impulse - Technology changes the typical crystal structure of scale - from a chaotic clutter into a well aligned mono-crystal. The water droplets are finer, which allows you to produce more snow with a better snow crystal structure that will last longer.

Better water characteristics for snowmaking

- ▶ Water surface tension decreases by 15 - 20%
- ▶ Vulcan produces mono-crystal nucleuses in the water that form organized, more stable ice and snow crystals
- ▶ Soft-water-characteristics result in finer mist and pulverization with finer droplets
- ▶ Vulcan prevents scale buildup in the pipe and the nozzles

Improvement of your snow production

Improvement of snow structure, water content, density, snow temperature and grain size

- ▶ Vulcan prevents scaling up of the cannon's spray nozzles
- ▶ Maximized production output with less water loss
- ▶ Finer snow crystals with a decrease of diameter (-20%) and a decrease of volume (-45%)
- ▶ The finer water droplets freeze earlier
- ▶ Snow is dryer as it contains less unfrozen water
- ▶ Smaller and dryer crystals have a lower temperature of approx. -2.5°C/ -4.5°F



What do you see on the slope?

- ▶ Snow production is already possible with a higher temperature
- ▶ Drier snow for a better skiing comfort
- ▶ Less icing with a more compact slope
- ▶ The finer crystals reflect more sunrays and therefore last longer in sunlight
- ▶ Rain water penetration is minimized
- ▶ Warm-air infiltration is minimized

Water as it should be for your snow production

Vulcan is specially designed for outdoor operation

as the electronic unit is protected by a 1.5" (~3.2 cm) thick solid acrylic cast. It is suitable to operate in very low temperatures, humidity, snow, ice and water. The installation of Vulcan is simple, as it sits outside of the water pipe.



How it works: The Vulcan-Impulse-Technology is based on the principle of physical water treatment. Special electronic impulses change the crystallization of the water elements. This minimizes the adhesiveness of the scale particles and at the same time produces mono-crystals that are ideal cores for snow crystal formation.



10.6 Cooling Towers

Water treatment: Cooling towers

Vulcan **eco-friendly** water treatment products are the chemical-free alternative to traditional water softeners in cooling tower applications



Water is a valuable resource which needs to be managed properly to maximize efficient usage. Water naturally forms scale when there is an increase in temperature or decrease in pressure. The resulting deposits reduce the effectiveness of cooling towers. Using toxic chemicals such as chlorine, phosphates and

acids is the traditional way to eliminate the scale problem; Vulcan is the eco-friendly alternative. Its electronic impulses alter the natural crystallization process of the calcium. Instead of burr-like structures (pic. 1), they form as simple mono crystals (pic. 2) and remain suspended in the water, unable to build up on surfaces.

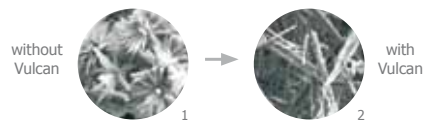

Advantages of using Vulcan

- ▶ Maximizes tower cycles
- ▶ Reduces water consumption
- ▶ Lowers overall operating costs
- ▶ Fewer maintenance visits
- ▶ Fewer or no chemicals needed
- ▶ Reduces bacteria and biofilm
- ▶ Maximizes life of equipment
- ▶ Fast amortization rate



As calcium and other solids do not evaporate, they remain in the cooling tower circuit. When make-up water is introduced, the solids remaining after its evaporation add to the already existing solids - building up more and more. Problems then occur, as these built-up solids typically clog up the system.

A significant reduction of scale deposits can be achieved by using Vulcan. Bleed water is no longer toxic and bacteria no longer have an ideal breeding ground. Furthermore, the cooling tower will be able to operate at higher cycles of concentration, lowering water usage.

Application Examples

- ▶ Production Facilities
- ▶ Office Buildings and High-Rises
- ▶ Universities
- ▶ Hospitals
- ▶ Hotels
- ▶ Airports
- ▶ Food and Beverage Processing
- ▶ Chemical Processing Plants
- ▶ Refineries

Installation Example-Open Circuit

Vulcan should be installed just before the heat exchanger. Please ensure to regularly drain the circuit at the bottom of the basin or use a centrifugal filter to take away remaining solids from the cooling tower water.

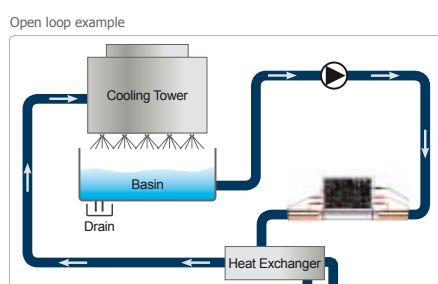

On closed loop circuits, Vulcan is located after the pump.

Case Study – Cooling Tower



“... After installation of the Vulcans, the status of the cooling towers was inspected without using any water treatment chemicals. Even after approximately six months, almost no scale buildup was observed inside the refrigerators and the heat exchanger tubes.

Calcium which was adhered on the cooling towers was easily removed with the wipe of a finger. With these results, the effectiveness of the Vulcan installation could be confirmed. ...”

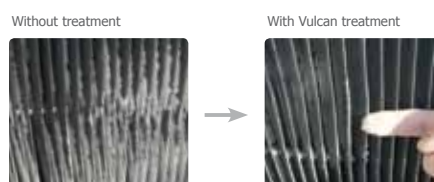

10.7 Reverse Osmosis Systems (RO)

When Vulcan is installed before a RO-system it helps in two ways:

1. As calcium-crystals are smoother after the Vulcan treatment, this reduces deposits on the sensitive RO-filter membranes. The RO-system runs longer and more effectively.
2. The permeate (leftover water) is difficult to handle as it has a particularly high degree of water hardness after filtration. Here, Vulcan helps that the reject water can be better handled and prevents it from causing damage further down the drain.



RO system

10.8 Vulcan and Water Softeners

In production and industrial settings, you may need a softener when there is no (zero) tolerance for any calcium in the water. However, in numerous cases, you can eliminate your softener and replace it with a Vulcan system. If you need to operate a softener, Vulcan can be installed as an addition which helps the softener's performance:

a) Vulcan replaces water softeners

Vulcan is the eco-friendly alternative to regular salt-based water softeners. The salt that is added to the water is polluting the environment and is not recommended for young children or older people to drink. The old system can usually easily be put out of use by simply bypassing it.

b) Vulcan as an addition to water softeners

Vulcan is the eco-friendly alternative to regular salt-based water softeners. However, if you want to keep the softener running due to special reasons, you can save large sums of money when using Vulcan as an aid. The use of Vulcan will decrease the amount of salt that you need to add. This cuts down costs for salt, maintenance intervals will be extended, less malfunctioning in the backwash valves etc.



Vulcan installation with water softener

10.9 Savings Potential in Machinery Operation

Vulcan improves the performance and efficiency of many machines that operate with water. The use of Vulcan saves you time and money from day one of the installation.

Six typical money saving areas

1. Scaling inside the machine is minimized.
2. If additives are used they are often more effective and last longer.
3. The machine can run longer before it needs to be serviced again. Often cleaning of the parts is much easier.
4. Less repairs and less need to replace individual parts.
5. Tanks that carry water or other liquids need less maintenance and cleaning thereof. Most of the time it is much easier and faster. This reduced service time results in fewer production breaks.
6. Less biofilm and bacterial growth allows a reduction of control measures and chemicals to combat this.



IV. Installation and FAQs

11. Vulcan Installation

11.1 Choosing the right Vulcan Size

When choosing the size please consider these two factors:

Pipe diameter and water capacity.

11.1.1 The pipe diameter

Where to look: Check the pipe diameter in the area where you want to install Vulcan. It does not matter if the pipe material changes (bigger or smaller) somewhere later on the piping system.

The Vulcan impulses treat the water as it flows by. It is important to submit the right impulse strength everywhere in the pipe so that all the water is treated correctly. The impulse should neither be too weak nor too strong. In order to provide exactly the right impulse strength for your pipe, Vulcan comes in several sizes. This ensures that the same strength of impulse is present throughout each individual pipe diameter. The impulse needs to reach equally to the outside rim of the pipe (A) as well as to the center (B) (pic. 1).

If you got it right:

Each Vulcan is designed so that the cleaning process is set to dismantle a fine layer of scale at a time. This "powder" is washed away by the water and ensures a gentle, secure cleaning.

If you got it wrong:

The problem of underperformance/ overperformance

If the Vulcan impulse is too weak: An insufficient (too weak) impulse will result in too little treatment. Therefore **Do NOT undersize the unit.**

If the Vulcan impulse is too strong: A too strong Vulcan impulse strength is not recommended. If an oversized Vulcan unit were installed to get an accelerated cleaning process (e.g. Vulcan S25 on a 1" pipe), the treatment would dismantle too much scale. This would lead to bigger pieces of scale being taken off the deposit which will potentially block your piping system overall. **Do NOT oversize the unit.**

The problem with substitution

You can not take two small units to substitute *one* big unit (e.g. two Vulcan 5000 do *not* replace one Vulcan S25). **Do NOT combine many small units instead of one large unit.**

Vulcan unit sizes	
max. 1½"	- Vulcan 3000
max. 2"	- Vulcan 5000
max. 3"	- Vulcan S10
max. 4"	- Vulcan S25
max. 6"	- Vulcan S100
max. 10"	- Vulcan S250
max. 20"	- Vulcan S500

Impulse penetration area

- A** outside rim
- B** pipe center
- C** A to B: distance penetrated by impulses

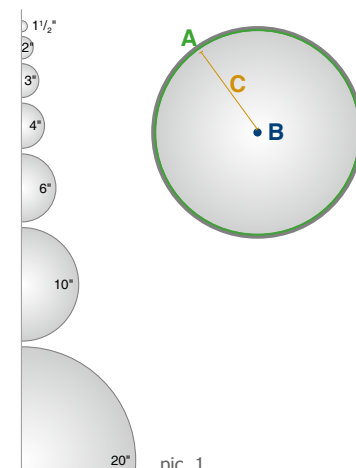

pic. 1

11.1.2 The water capacity

The maximum water capacity per hour (l/h, m³/h, gph or gpm) is the amount of water that Vulcan is capable of treating within one hour. This number is largely determined by the pipe diameter itself: The diameter of the pipe together with the maximal amount of water pressure (usually 20 bar) determines the maximum capacity of each specific pipe size.

unit size	Vulcan 3000	Vulcan 5000	Vulcan S10	Vulcan S25	Vulcan S100	Vulcan S250	Vulcan S500
max. water capacity*	3000 l/h 793 gph	5000 l/h 1325 gph	10 m ³ /h 44 gpm	25 m ³ /h 110 gpm	100 m ³ /h 440 gpm	250 m ³ /h 1100 gpm	500 m ³ /h 2200 gpm

* plus 20% tolerance



Most of the times - especially in private installations your client will probably not consume the possible max. capacity (eg. Vulcan 5000 with the max. of 5000l/h). However, in certain peak times, this will be the hourly usage for a short period. The maximum capacity is reached at the moment of *simultaneous consumption* (peak consumption). For example, a peak moment is reached when the kitchen water is running, someone is taking a shower and the the washing machine is in operation. As production processes are carefully designed to meet exact requirements, it is more common for industrial production lines to consume the maximum of their pipe diameter capacity over long periods. For example, in a production it is more likely that a 4" pipe is constantly transporting the maximum amount of water – simply because it has been exactly designed for that.

20% Tolerance

The maximum capacity information is not fixed. With the right installation setting and with no external factors hindering the impulse treatment, Vulcan effectively treats up to 20% more water. This means, there is a **20% tolerance factor**.

Example: The Vulcan S25 is designed for a 4" pipe diameter and a max. capacity of 25m³/h (~110 gpm). If the setting is favorable, Vulcan treats up to 30 m³/h (= 20% more).

11.2 Choosing the right Installation Location

11.2.1 Installation in a private house

Vulcan is typically installed at the point where the main water supply line enters the building. Most of the time, this is close to the water meter or the main shut-off valve. This way, the Vulcan treatment takes place before the water is distributed into the building.

European homes usually have a basement and the main water pipe is accessible easily. The installation thus is very simple. Many other homes around the world have the water access outside the house. This also is usually where water meter is located. CWT also offers a range of additional equipment such as mounting boxes that can protect the unit from theft and weather.

If the house is equipped with a storage water tank (many times located on the roof), we recommend the installation of Vulcan after the tank outlet. This ensures that the water is treated just before it travels through the piping system. If Vulcan were installed before the tank and the water had been sitting for 2-7 days in the tank before usage, the Vulcan effect might get lost in the tank.

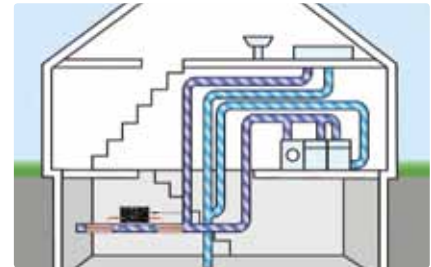

Basement installation

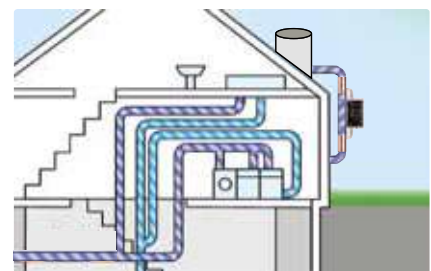

Storage tank installation

11.2.2 Installation in apartment buildings

In general, the same installation guideline as for private houses applies to larger buildings: Vulcan is installed at the point where the incoming water supply line is going into the building (typically close to where the water meter is placed). Please also consider other factors such as the construction plan of the water carrying pipes and heating system. If you have an extra system for heating, you may need another unit for the hot water circulation line. The unit size should be according to pipe diameter and water flow.



Vulcan installation in an apartment building

11.2.3 Installation in commercial & industrial settings

Due to the different nature of production sites, there is no standard rule for installation. As a production site typically consists of a number of buildings, the main building can be treated as any other large building. We recommend the installation of a large unit to treat the main water industrial usage inlet. This is a basic treatment and additional smaller Vulcan units should be installed right before the worst scale problem generating machinery (heat exchangers, cooling towers, chillers, production lines, ...). Please contact us, if you need technical assistance.



Vulcan installation in a factory

11.2.4 Installation in circulation lines

If you have a circulation line either open, semi-closed or closed-loop line, there should be an extra Vulcan unit placed there. The water in circulation travels long distances and the circulation pumps often suffer severely from scale deposits. The Vulcan size needs to be selected according to the pipe size of the circulation.

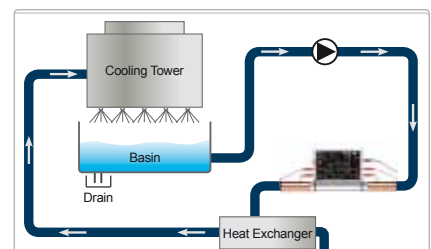

Open loop circulation line

11.3 Factors influencing the Installation Location

11.3.1 Electric power fields and magnetic fields

Please make sure that there are no strong electric lines running close to the installation area. High voltage electric lines or strong magnetic fields may interfere with the Vulcan impulse field.

Private houses typically do not have such strong electric lines (except supply for electric ovens); these should run at sufficient distance away from the installation area.



11.3.2 Position of pumps and filters

Pumps

Magnetic or electrical fields can exist in electric motors or in certain types of water pumps. As a general rule, we therefore recommend to choose an installation area at least 50 cm (20") away (ideally after) electric motors or pumps, if the setting in your installation area allows it.

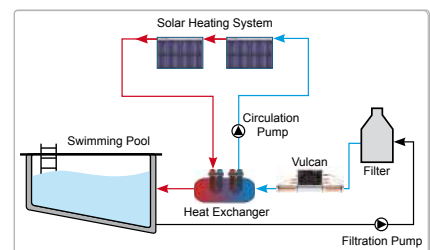

Filters

Some filters may block the mono-calcium crystals that are supposed to travel through the piping system. Crude filters ($> 50 \mu$) do not remove the mono-crystals and can be ignored. However, for more sensitive filters ($< 5-50 \mu$) it is recommended to install Vulcan after the filter.

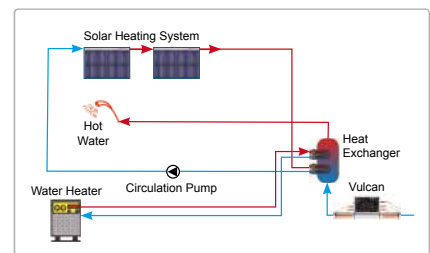

11.3.3 Piping conditions of the installation area

Protective paint

Thick coatings like pipe protection (e.g. many layers of corrosion protection paint) are not suitable for an installation. We recommend removing thick layers of paint with sand paper prior to the installation of a Vulcan unit.



Isolation material

Isolation material should be dismantled before the installation of a Vulcan unit. After the installation it is good to replace the material as an additional protection of the impulse bands.



Metallic splinters

Especially in an industrial setting you might be faced with uneven pipe surfaces on the outside of the pipe. Metallic splinters can cause pitting of the impulse bands and splinters should be treated with sand paper prior to the installation.

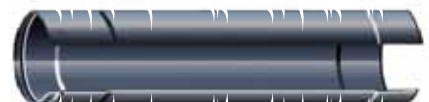

Piping temperature

If the pipe that Vulcan should be installed on is carrying hot water, please check that the pipe's outside temperature does not exceed 65°C (149°F). Temperatures above this may harm the isolation of the copper impulse bands.

Pipe Temperatures over 65°C/ 150°F

The installation of Vulcan directly on the hot water pipe (with more than 65°C/ 150°F) can be easily adapted. Please place a piece of plastic or wood material under the Vulcan acrylic electronic unit in order to shade it from the pipe's heat. In order to protect the Vulcan impulse band from excessive heat, please place plastic foil on the pipe before installing the impulse bands on top. Regular plastic wrap available in the supermarket works great to shade off the heat. Please see the picture.

As a rule of thumb: when the pipe's surface can not be touched with your hand = 65°C/ 150°F, then it is wise to use this set up.

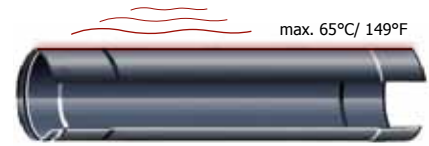

11.3.4 Outdoor installation

Vulcan is suitable for outdoor installation. It operates at temperatures between -25°C and +50°C (-13° to 112°F).

In any outdoor setting we advise protecting the acrylic main unit from direct sunlight or direct rain. The **Vulcan outdoor cases** are available in several sizes and come with either a transparent or an opaque lid. They offer an additional protection against heat, rain and other external factors. As the non-transparent box hides the product it makes attempts of theft less likely.



Vulcan outdoor installation



Vulcan protection casing



Vulcan installation with a protection case

Solar power panels

The outdoor installation setting sometimes demands a convenient power supply. CWT offers solar power panels that run on 24V (5W) that can easily be installed in any outdoor scenario. They are backed up by a battery to secure a full 24h power cycle.



Solar power panel

11.4 Quick Guide: Do-It-Yourself-Installation

Vulcan is especially designed so that the installation does not need to be done by a specialized plumber. You can easily install Vulcan in approx. 10-15 minutes. The installation does not require any tools and there is no need to cut the pipe.

11.4.1 Notes on the installation and examples

1. For optimal water treatment Vulcan is best installed near the water meter or at the main water supply.
2. The impulse band windings can be placed on the left side, on the right side or underneath the electronic device. Leave a safe distance of at least 1 cm (min. $\sim 1/2''$) from the band pairs.
3. Vulcan can be installed vertically, horizontally or at any other angle. If there is no space available on the pipe the device can also be wall-mounted.
4. In case of limited space the windings can be placed partly on the main pipe and partly on the distributor pipe.

All these different installations are possible because the treatment impulses extend over several meters to either side of the pipes.

11.4.2 General information

1. Protect the power supply unit against exposure to direct water.
2. Use the included switching power supply unit only.
3. Do not cut the impulse bands nor the 24 V power cord of the power supply unit.
4. Do not remove the end caps or the impulse band insulation.
5. The operating temperature of Vulcan ranges from -25°C to $+50^{\circ}\text{C}$ (-13°F to 122°F).
6. Clean the device with water only.
7. Temperature peaks on heating element surfaces should not exceed 95°C (203°F).

11.4.3 Installation instructions for the Private Line

1. Put the two band holders through the fixing holes at the bottom of the electronic device. Now place the device onto the pipe. Use the band holders to latch the device to the pipe.
2. Connect one of the impulse bands to the device and use another band holder to latch it to the pipe.
3. Wind the impulse bands around the pipe producing a coil. Make sure you wind the band tightly to the pipe and place the windings close to each other.
4. Latch the end of the band to the pipe using another band holder. Now repeat the procedure with the second impulse band.
5. First plug the connector into the upper right in-jack of the device and then connect the power supply unit with an electrical outlet.
6. The red pilot lights will illuminate as soon as the device starts to operate. Vulcan works from now on maintenance free.

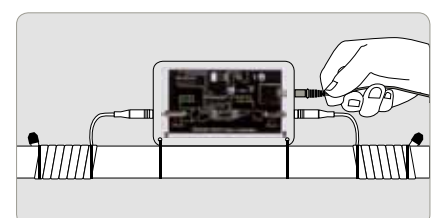
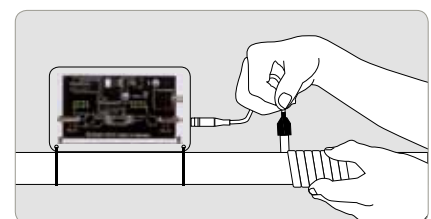
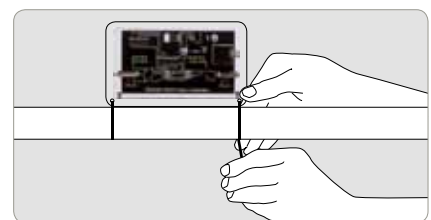
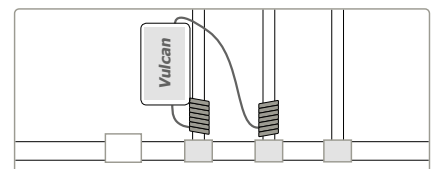
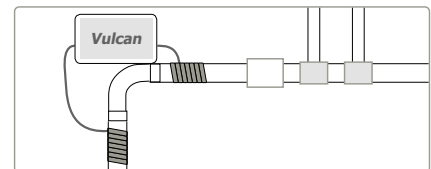
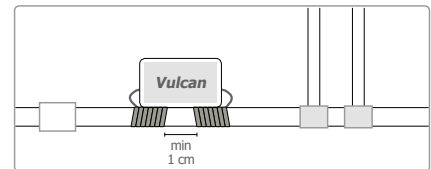
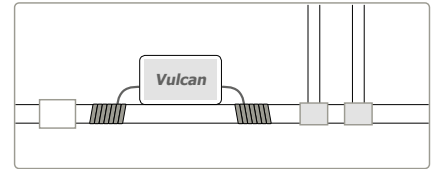

11.4.4 Installation instructions for the Commercial & Industrial Line

1. Put the two band holders through the fixing holes at the bottom of the electronic device. Now place the device onto the pipe. Use the band holders to latch the device to the pipe.
2. Plug one of the impulse bands into the bottom impulse band in-jack and latch it to the pipe using another band holder.
3. Wind the impulse bands around the pipe producing a coil. Make sure you wind the band tightly to the pipe and place the windings close to each other.
4. Latch the end of the band to the pipe using another band holder. Now plug another impulse band into the in-jack on the opposite side and repeat the procedure.
5. Plug another impulse band into the next impulse band in-jack and, according to the device type, repeat steps 2 - 4 until all impulse bands are in use. All impulse bands must be wound tightly around the pipe and fastened with band holders.
6. First plug the connector into the upper right in-jack of the device and then connect the power supply unit with an electrical outlet.
7. Now adjust your Vulcan on the side sensors according to your pipe diameter to optimally treat your water.

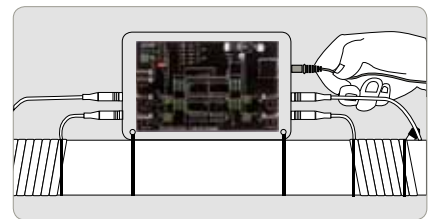
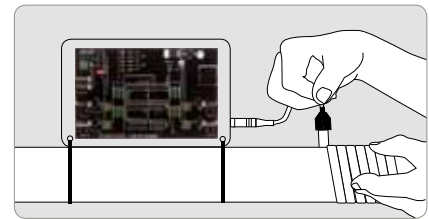
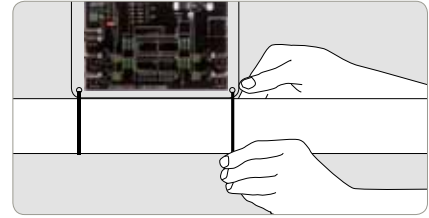

See section 12 for program setting.

The CWT Impulse Detector

Show what is going on, if you have a impulse detector with you.

The detector is a good tool when you show Vulcan to new customers. With the audio perception, the client gains a better understanding of the impulse treatment.

When you hold the detector close to the impulse cables you can check the functionality of Vulcan.

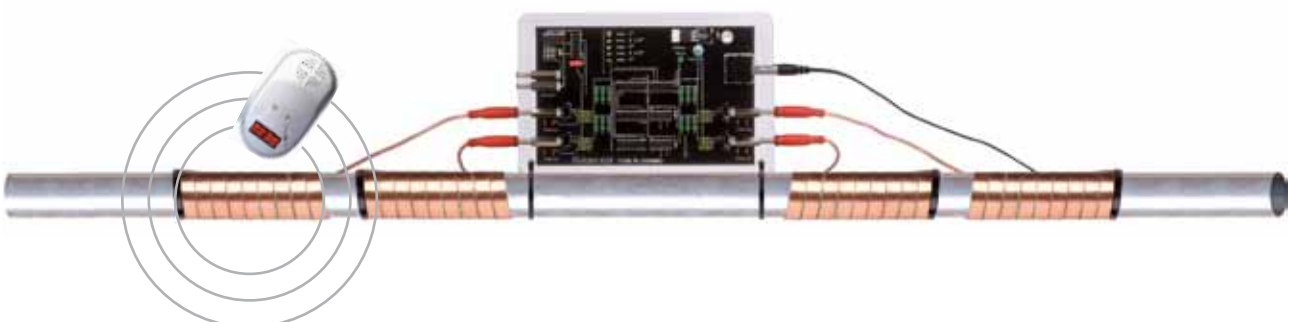

11.4.5 Technical drawings

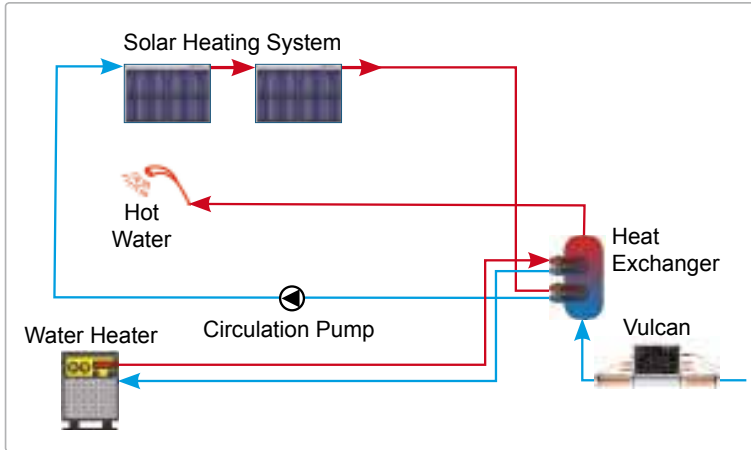

Solar Water Heating System

For best results, Vulcan should be placed on the cold water inlet to the heat exchanger.

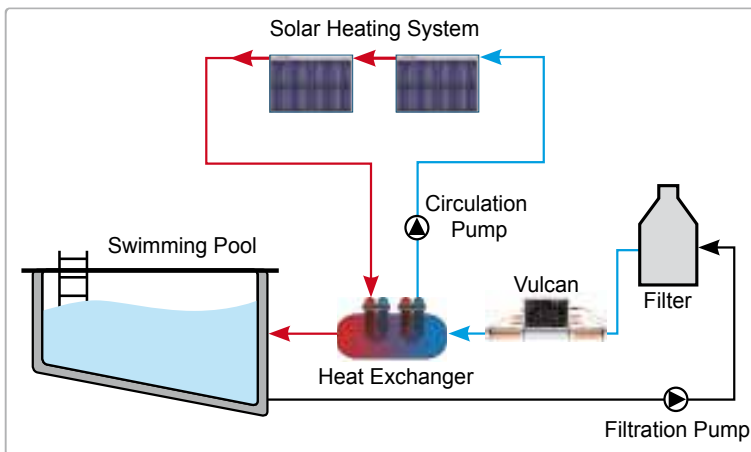

Solar Pool Heating and Filtration System

For optimal results, Vulcan should be placed between the filter and the heat exchanger.

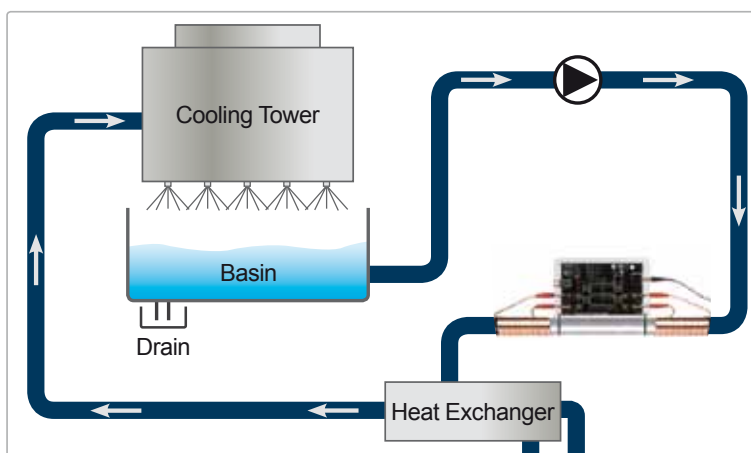

Cooling Towers

Installation Example-Open Circuit

Vulcan should be installed just before the heat exchanger. Please ensure to regularly drain the circuit at the bottom of the basin or use a centrifugal filter to take away remaining solids from the cooling tower water.

On closed loop circuits, Vulcan is located after the pump.

12. Setting the Programs

Vulcan provides a selection of programs in the Commercial (S10, S25, S100) and Industrial units (S250, S500).

A program is set by touching both metal plates on the left side of the unit. The fingers bridge the gap between the two plates and set the switch. Tap once, the program locks into the next position which is indicated by the green control light. Tap again and the program jumps to the next program and so on.

The pipe material determines how good the electric Vulcan impulses pass through the pipe's wall. As electricity penetrates plastic easier than metal, the impulse signal is stronger for metal pipes than for plastic pipes. This is reflected in the programs. They allow a fine-tuning of the Vulcan impulse which adjusts the impulse strengths according to diameter and pipe material.



Touch both metal plates to set the program

12.1 Commercial Line - Vulcan S10, Vulcan S25, Vulcan S100

Vulcan S10 Programs

- max. 2"
- max. 2 1/2"
- max. 3"

Vulcan S25 Programs

- max. 2"
- max. 2 1/2"
- max. 3"
- max. 3 1/2"
- max. 4"

Vulcan S100 Programs

- | | |
|---------------------|-----------------------|
| • max. 2 1/2" Metal | • max. 2 1/2" Plastic |
| • max. 3" Metal | • max. 3" Plastic |
| • max. 4" Metal | • max. 4" Plastic |
| • max. 5" Metal | • max. 5" Plastic |
| • max. 6" Metal | • max. 6" Plastic |

12.2 Industrial Line - Vulcan S250, Vulcan S500

Vulcan S250 Programs

- | | |
|------------------|--------------------|
| • max. 4" Metal | • max. 4" Plastic |
| • max. 5" Metal | • max. 5" Plastic |
| • max. 6" Metal | • max. 6" Plastic |
| • max. 8" Metal | • max. 8" Plastic |
| • max. 10" Metal | • max. 10" Plastic |

Vulcan S500 Programs

- | | |
|------------------|--------------------|
| • max. 8" Metal | • max. 8" Plastic |
| • max. 10" Metal | • max. 10" Plastic |
| • max. 12" Metal | • max. 12" Plastic |
| • max. 16" Metal | • max. 16" Plastic |
| • max. 20" Metal | • max. 20" Plastic |



Installation check List

Client/ Company _____

Contact Person _____

- Vulcan: S25
 3000 S100
 5000 S250
 S10 S500

Installation date _____

Pipe diameter _____

Pipe material _____

1. Is the installation place chosen with respect to these factors?

Time Factor / Heat Factor / Distance Factor

OK

2. Are there unusual high levels of certain substances in the water? If yes, have they be taken care of?

Fe: The iron concentration in the water should not exceed 1 mg/l (1 ppm)

Mn: The manganese level should not exceed 0.1 mg/l (0.1 ppm)

OK

3. Have the location of filters and pumps been taken into consideration?

As a general rule it is better to install Vulcan after a pump and after a filter, if the setting in your installation area allows it.

Filters: Crude filters (> 50 µ) do not remove the mono-crystals and can be ignored. For more sensitive filters (< 50 µ) it is recommended to install Vulcan after the filter.

Pumps: If possible, we advise installing Vulcan after any pumps.

OK

4. Have you checked for strong electricity, magnetic fields or electro-motors?

Please make sure that there are no strong electric lines running close to the installation area.

High voltage electric lines or strong magnetic fields may interfere with the Vulcan impulse-field.

OK

5. Are paint or cover materials on the pipe taken care of?

- Thin coatings such as pipe protection (e.g. corrosion protection paint) are suitable to place the impulse-bands directly on top.

- Insulation material or other thicker protective layers should be dismantled and can be re-installed over the impulse bands after installation.

OK

6. Is the pipe surface temperature suitable?

The pipe's outside temperature should not exceed 65°C (~ 149° F). Above this may harm the isolation of the copper impulse bands.

OK

14. FAQs - Frequently Asked Questions

14.1 The Piping System

What type of pipe material does Vulcan treat?

Vulcan is suitable for all pipe materials: iron, galvanized iron, inox, copper, steel, stainless steel, plastic, PVC, PE-X, compound pipes (any material mixture) etc.

Do plastic pipes and copper pipes need scale protection at all?

Yes. Plastic and copper pipes are prone to calcifications, too. The smoother a surface is the longer it can resist the process of calcification. It may take longer until plastic or copper get a first layer of scale. However, once that first layer has built up, the scaling process proceeds just as fast as on any other surface or material.

How long does it take Vulcan to sanitize the pipes?

Vulcan gently removes scale and rust without negatively affecting the pipes. The treatment works within the laws of nature. Therefore, the removal process may take as long as it took the deposits to develop.

Will the scale that is cleaned out block the pipes?

No, the scale is slowly dissolved back into a solution and the calcium and magnesium is washed away in the water as a fine powder.

How long does the effect last?

When mono-crystals are created by the impulse variation, it is important that they grow as long as possible before they start their way through the piping system. The larger the crystals, the longer it takes until the crystals fall apart again and eventually "die". In warm water, these crystals grow faster and therefore are stronger and live longer. This explains why the Vulcan-effect lasts the longest in warm water (up to seven days) and shorter in cold water (approx. two days).

The copper pipes have turned green. Does Vulcan help with this problem? Green colored copper pipes are an indication to oxidized copper or copper rust - similar to rust in iron pipes. The Vulcan treatment produces hydrogen dioxide (H_2O_2) which protects blank copper surfaces against oxidation. This way, Vulcan reduces the green colorization of the water.



14.2 The Water Quality

How do I know the water hardness of my water?

Your local waterworks provides detailed information on the chemical composition of your water. It lists the calcium and magnesium content and usually provides information on hardness in gpg (grains per gallon) or in ppm (parts per million). More: Hardness classifications in appendix

Up to which degree of water hardness can Vulcan be applied?

Vulcan operates within a high performance frequency range and is the only unit with a 24 Volt technology. It can thus be successfully applied to problems with a very high degree of water hardness. Vulcan has successfully treated cases with a water hardness of 1000 ppm (~ 59 gpg) or more.



Does the Vulcan treatment have a softening effect on the water?

The treatment does not change the overall water hardness. Unlike in chemical water treatment systems (e.g. a water softener that uses salt) the water treated by Vulcan does not lose minerals, such as calcium and magnesium. The natural composition of the elements in the water remains the same. However, due to a change of the water surface tension your skin will feel remarkably softer. You are sure to feel this effect when taking a shower or even simply washing your hands. Most importantly, scale loses its adhesive characteristic. The treatment does not, however, change the measured water hardness. So on a chemical level you have the same hardness before and after the treatment.

14.3 Installation and Operation

Is it difficult to install Vulcan in my home? Vulcan is designed as a do-it-yourself product. It sits outside the pipe and you do not need to cut into the pipe. The installation is very easy and takes approx. 10 minutes. No tools required.

How do I know which Vulcan size is needed for my application?

Please check the pipe diameter in the area where you want to install Vulcan. Then choose the unit that is designed for this size.

Where should I install Vulcan in my home? Vulcan is mounted outside of the pipe with no need to cut the pipe. It should be installed at the point where the incoming water supply line is going into the house. Most of the time this is close to the water meter. This way, a single Vulcan treats all the water pipes in the house.

European homes usually have a basement, so the main water pipe sits somewhere there, inside the house. Many homes allow access only outside the house. This again is usually where the water meter is located. Vulcan is a waterproof unit suitable for outdoor installation. We also offer a range of additional features such as a solar power charger in case that there is no power supply nearby.

How do I know that the Vulcan is operating efficiently?

Red pilot lights at the impulse band outputs indicate that the impulse generator is operating efficiently. In case these lights are not illuminated, please check the power supply voltage or contact your local distributor.

Which voltage ranges are suitable for the electronic power supply unit?

All Vulcan power supply units are suitable for voltage ranges between 87 Volt – 260 Volt and 50 Hz – 60 Hz. It can therefore easily cater to all international power plugs. We are glad to supply you with the correct power supply unit in case of an international relocation.

How many units do I need? Private homes are taken care of with one unit that treats the whole house. In larger buildings or industrial settings it depends. Typically, one larger unit gets installed on the incoming water supply line to the building. If you have a cooling tower or closed loop systems, another smaller unit would go there.

What are the power costs of Vulcan per year?

Vulcan is completely maintenance-free. The cost of electric energy per year amounts to approx. 4-5 € (~\$ US 5-7).



14.4 Miscellaneous

What kind of warranty do I get on Vulcan?

Vulcan has a full 10-year warranty and has a 30+ year life span. It is German TÜV-certified and is CE, CUL and UL listed. Your Vulcan unit is 100% covered under most circumstances. The units have an expected life of over 30 years and are imbedded in weather proof acrylic casts. By purchasing from the manufacturer and listed distributors, your warranty is well-assured. German quality standards and excellent customer service have been our priority for over 60 years.

I heard of similar products which don't work. Can you explain?

There are similar products to Vulcan on the market that claim to do the job, but don't. Almost all other products on the market are working with inductive (electromagnetic) technologies. You can easily recognize them by their cables. Those cables run in a loop from the electronic unit - to the pipe and back into the unit (pic. 1).

In comparison, Vulcan works exclusively with capacitive impulses that guarantee a stable output. Its impulse bands end on the pipes, similar to antennas. Furthermore, regardless of inductive or capacitive impulses: Vulcan utilizes far wider frequencies of 3,000 - 32,000 Hz (= 3-32 kHz) and operates with energy levels at 24V. Read more on the differences in technologies on page 16. Christiani Wassertechnik (CWT) is the oldest German manufacturer of physical water treatment. The product specialization in this field began in 1977 and we are constantly developing new technologies.

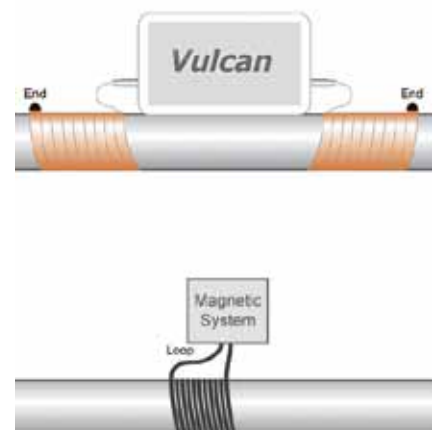

pic. 1

14.5 Trouble Shooting

green red

The green light is off/ the red lights are off

The single green light indicates the correct power supply. If it is off, there is no active power supply and Vulcan can not function. This could be caused by a malfunctioning of the power plug. Please check if the power plug is correctly connected to the power source. Also please check if the impulse bands are without damage. If both are in order, the electric power adaptor may be malfunctioning.

Green light is active/ all red pilot lights are off

The flashing of the red pilot lights indicates that the impulse generation is operating correctly. Although the power supply is active, if the red lights are off, the impulse generation may not be performing correctly. In this case, please contact the CWT office.

The green light is off/ the red lights are on

Although the green light is not illuminated which indicates the absence of power, the red lights approve the correct impulse generation. In this case, the green lamp is simply out of order due to a lamp malfunctioning.



My client installed Vulcan some days or weeks ago and now finds small particles and pieces in the aerator. This is a normal effect. The first layer of scale deposits inside the pipe are quite loose and crumble off easily. It is typical that they can be found within the first weeks of the operation. After that initial loose layer has been dismantled, you will normally not be able to notice any of the deposit removal as the scale is dissolved in the water and washed away.



My client came home after a vacation and when he turned on the water for the first time, it showed a red color. As the water in the house has been sitting in the pipe for some days or weeks it was soaking up the rusty color of the deposit. You will then see the red color until all water in the piping has been flushed out and new water is pumped through after that. This is not at all caused by Vulcan. Rather, the existence of red water in such a case simply proves that there are rusty deposits in the piping system. Vulcan will slowly dissolve them.



The top layer of the acrylic cast looks dull or yellowish. There are several possible reasons for a decolorization of the acrylic surface: Cleaning the Vulcan surface should only be done with a wet cloth and with no cleaning additives. A common mistake is to use a glass cleaner (e.g. windex) which harms the material. Another possible reason is direct exposure to sunlight. This can also discolor the surface. However, this is a cosmetic problem and does not influence the effectiveness of the treatment. CWT offers a repolishing service in such cases for a small fee.



My client tells me that he thinks the unit has been working great for a while (some months/ years) but seems to loose its effectiveness. What could be the reason behind this? And how can I check whether or not it is working? In order to verify results, in such cases, we advise you to provide your client with a new aerator for one of the faucets (e.g. for the bathroom). Please ask your client to send it back to you after a time-period of 12 weeks. How the aerator looks after that time is a very good indicator for the performance of Vulcan.

Furthermore, we advise unplugging Vulcan for a period of 4-8 weeks and then putting it into operation again. A rare but common phenomenon is that people get used to the Vulcan effect in the water after time - they lose their original objectivity. By stopping Vulcan for a while, the „normal“, untreated water will show its typical problems again. When Vulcan is then put into operation again, the change will be obvious.

V. Appendix

15. Water Hardness Classification

Water hardness	ppm Parts per million (mg/l)	GPG Grains per gallons (US)	°dH German hardness
very soft	1-70	1.0 - 4.2	1.0 - 4.0
soft	71-125	4.3 - 7.2	4.1 - 7.9
medium hard	126-250	7.3 - 22	8.0 - 14
hard	251-500	23 - 30	15 - 21
extremely hard	501 and more	31 and more	22 and more

	ppm	°dH	GPG	°fH
very soft	20	1,1	1,2	2
	40	2,2	2,3	4
	60	3,4	3,5	6
	80	4,5	4,7	8
soft	100	5,6	5,8	10
	120	6,7	7,0	12
medium hard	140	7,8	8,2	14
	160	9,0	9,3	16
	180	10,1	10,5	18
	200	11,2	11,7	20
	220	12,3	12,9	22
hard	240	13,5	14,0	24
	260	14,6	15,2	26
	280	15,7	16,4	28
	300	16,8	17,5	30
	320	17,9	18,7	32
	340	19,1	19,9	34
	360	20,2	21,0	36
	380	21,3	22,2	38
	400	22,4	23,4	40
	420	23,5	24,5	42
	440	24,7	25,7	44
	460	25,8	26,9	46
	480	26,9	28,0	48
	500	28,0	29,2	50
	extr. hard	520	29,1	30,4
540		30,3	31,5	54
560		31,4	32,7	56
580		32,5	33,9	58
600		33,6	35,1	60
620		34,8	36,2	62
640		35,9	37,4	64
660		37,0	38,6	66
680		38,1	39,7	68
700		39,2	40,9	70
720		40,4	42,1	72
740		41,5	43,2	74
760		42,6	44,4	76
780		43,7	45,6	78
800		44,8	46,7	80
820	46,0	47,9	82	
840	47,1	49,1	84	
860	48,2	50,2	86	
880	49,3	51,4	88	
900	50,4	52,6	90	

	GPG	ppm	°dH	°fH
very soft	1	17	1,0	1,7
	2	34	1,9	3,4
	3	51	2,9	5,1
	4	68	3,8	6,8
soft	5	86	4,8	8,6
	6	103	5,8	10,3
	7	120	6,7	12,0
medium hard	8	137	7,7	13,7
	9	154	8,6	15,4
	10	171	9,6	17,1
	11	188	10,6	18,8
	12	205	11,5	20,5
	13	223	12,5	22,3
	14	240	13,4	24,0
hard	15	257	14,4	25,7
	16	274	15,3	27,4
	17	291	16,3	29,1
	18	308	17,3	30,8
	19	325	18,2	32,5
	20	342	19,2	34,2
	21	359	20,1	35,9
	22	377	21,1	37,7
	23	394	22,1	39,4
	24	411	23,0	41,1
	25	428	24,0	42,8
extr. hard	26	445	24,9	44,5
	27	462	25,9	46,2
	28	479	26,9	47,9
	29	496	27,8	49,6
	30	514	28,8	51,4
	31	531	29,7	53,1
	32	548	30,7	54,8
	33	565	31,7	56,5
	34	582	32,6	58,2
	35	599	33,6	59,9
	36	616	34,5	61,6
	37	633	35,5	63,3
	38	650	36,4	65,0
	39	668	37,4	66,8
40	685	38,4	68,5	
41	702	39,3	70,2	
42	719	40,3	71,9	
43	736	41,2	73,6	
44	753	42,2	75,3	
45	770	43,2	77,0	

	°dH	ppm	GPG
very soft	1	18	1,0
	2	36	2,1
	3	54	3,1
	4	71	4,2
soft	5	89	5,2
	6	107	6,3
	7	125	7,3
medium hard	8	143	8,3
	9	161	9,4
	10	178	10,4
	11	196	11,5
	12	214	12,5
	13	232	13,6
	14	250	14,6
hard	15	268	15,6
	16	285	16,7
	17	303	17,7
	18	321	18,8
	19	339	19,8
	20	357	20,9
	21	375	21,9
	22	392	22,9
	23	410	24,0
	24	428	25,0
	25	446	26,1
	26	464	27,1
	27	482	28,2
	28	500	29,2
	29	517	30,2
extr. hard	30	535	31,3
	31	553	32,3
	32	571	33,4
	33	589	34,4
	34	607	35,4
	35	624	36,5
	36	642	37,5
	37	660	38,6
	38	678	39,6
	39	696	40,7
	40	714	41,7
	41	731	42,7
	42	749	43,8
	43	767	44,8
	44	785	45,9
	45	803	46,9

°dH German Hardness
°fH French Hardness

ppm parts per million (mg/l)
GPG grains per Gallon (us)

16. Technical Data Overview



	Vulcan 3000	Vulcan 5000	Vulcan S10	Vulcan S25	Vulcan S100	Vulcan S250	Vulcan S500
Max. pipe diameter	1½" 38 mm	2" 50 mm	3" 76 mm	4" 100 mm	6" 150 mm	10" 250 mm	20" 500 mm
Max. capacity	800 gph 3000 l/h	1350 gph 5000 l/h	45 gpm 10 m³/h	110 gpm 25 m³/h	450 gpm 100 m³/h	1100 gpm 250 m³/h	2200 gpm 500 m³/h
Voltage	24 Volt	24 Volt	24 Volt	24 Volt	24 Volt	24 Volt	24 Volt
Wattage	2.0 Watt	2.0 Watt	2.25 Watt	2.25 Watt	2.5 Watt	2.75 Watt	3.25 Watt
Impulse bands	2 x 3' 3" 2 x 1 m	2 x 3' 3" 2 x 1 m	2 x 3' 3" 2 x 1 m	4 x 6' 7" 4 x 2 m	6 x 13' 2" 6 x 4 m	8 x 32' 9" 8 x 10 m	10 x 98' 5" 10 x 30 m
Band width	0.4" 10 mm	0.4" 10 mm	0.8" 20 mm	0.8" 20 mm	0.8" 20 mm	0.8" 20 mm	0.8" 20 mm
Measurements	3.1/5.1/1.2" 80/130/30 mm	3.3/5.9/1.2" 85/150/30 mm	4.7/7.5/1.6" 120/190/40 mm	4.9/7.9/1.6" 125/200/40 mm	5.6/9.4/1.6" 150/240/40 mm	7.9/11.6/2.0" 200/295/50 mm	8.7/12.6/2.0" 220/320/50 mm
Frequency range	3-32 kHz	3-32 kHz	3-32 kHz	3-32 kHz	3-32 kHz	3-32 kHz	3-32 kHz
Required space	11" 300 mm	1' 2" 350 mm	1' 8" 500 mm	1' 12" 600 mm	3' 11" 1200 mm	8' 3" 2500 mm	16' 5" 5000 mm
Programs	1	1	3	5	10	10	10

